



User Guide

MD810 Series

Standard Drive (Multidrive System)



User Guide

Preface

Thank you for purchasing the MD810 series drive (multidrive system) developed and manufactured by Shenzhen Inovance Technology Co., Ltd.

The MD810, a new generation low voltage multidrive system, is a common DC bus drive system consisting of a power supply unit and multiple drive units. It is applicable to applications such as a single mechanical device with multiple drive points or continuous production line system. It is widely used in metal products, printing and packaging, textile printing and dyeing, chemical fiber and plastics, EU small- sized papermaking, hoisting, and other industries.

The MD810 series drive unit must be used with an MD810 power supply unit. This guide only describes the product information, installation, communication, troubleshooting and parameters of the MD810 drive. For detailed information on the power supply unit, see 19010680 "810 Series Power Supply Unit User Guide."

The MD810 series drive (multidrive system) can be a single-axis or dual-axis drive unit. The drive has two designs: booksize and vertical tower in four sizes. See the following table for details.

Type	Structure	Width	Power
Drive unit (single-axis)	Booksize	50 mm	1.5–7.5 kW
		100 mm	11–37 kW
		200 mm	45–75 kW
		300 mm	90–160 kW
	Vertical tower	180 mm	90–160 kW
		230 mm	200–355 kW
Drive unit (dual-axis)	Booksize	50 mm	1.5–5.5 kW
		100 mm	7.5–18.5 kW



■ First-time Use

For users who use this product for the first time, read the guide carefully. If you have any problem concerning the functions or performance, contact the technical support personnel of Inovance to ensure correct use.

■ Approvals

The following table lists the certificates and standards that the product may comply with. For details about the acquired certificates, see the certification marks on the product nameplate.

Certification	Directives		Standard
CE	EMC directives	2014/30/EU	EN 61800-3
	LVD directives	2014/35/EU	EN 61800-5-1
	RoHS directives	2011/65/EU	EN 50581
TUV	-		EN 61800-5-1



NOTE

- ◆ The above EMC directives are complied with only when the EMC electric installation requirements are strictly observed.
- ◆ Certification marks on the product nameplate indicate compliance with the corresponding certificates and standards.
- ◆ Machines and devices used in combination with this drive must also be CE certified and marked. The integrator who integrates the drive with the CE mark into other devices has the responsibility of ensuring compliance with CE standards and verifying that conditions meet European standards.
- ◆ For more information on certification, consult our distributor or sales representative.

Revision History

Date	Version	Change Description
February 2017	A00	First issue.
September 2017	A01	Added parameters and updated diagrams.
December 2017	A02	Deleted description of the power supply unit. Added "Table 1-3 Selection of peripheral electric elements for MD810 series drive" and "Table 3-2 Recommended cable dimensions and tightening torque".
December 2018	A03	Added information of the 300 mm booksize model.
April 2019	A04	Added information of the 230 mm vertical tower model. Added error codes E25.12 to E25.61. Added a cause and corresponding solution for error code E10.00. Added parameters related to the resolver. Updated function definition of communication ports RJ45A/RJ45B.

Safety Instructions

Safety Precautions

- 1) Before installing, using, and maintaining this equipment, read the safety information and precautions thoroughly, and comply with them during operations.
- 2) To ensure the safety of humans and equipment, follow the signs on the equipment and all the safety instructions in this user guide.
- 3) "CAUTION", "WARNING", and "DANGER" items in the user guide do not indicate all safety precautions that need to be followed; instead, they just supplement the safety precautions.
- 4) Use this equipment according to the designated environment requirements. Damage caused by improper usage is not covered by warranty.
- 5) Inovance shall take no responsibility for any personal injuries or property damage caused by improper usage.

Safety Levels and Definitions



DANGER

indicates that failure to comply with the notice will result in severe personal injuries or even death.



WARNING

indicates that failure to comply with the notice may result in severe personal injuries or even death.



CAUTION

indicates that failure to comply with the notice may result in minor personal injuries or damage to the equipment.

Safety Instructions

Unpacking



CAUTION

- ◆ Check whether the packing is intact and whether there is damage, water seepage, damp, and deformation.
- ◆ Unpack the package by following the package sequence. Do not hit the package with force.
- ◆ Check whether there are damage, rust, or injuries on the surface of the equipment or equipment accessories.
- ◆ Check whether the number of packing materials is consistent with the packing list.

**WARNING**

- ◆ Do not install the equipment if you find damage, rust, or indications of use on the equipment or accessories.
- ◆ Do not install the equipment if you find water seepage, component missing or damage upon unpacking.
- ◆ Do not install the equipment if you find the packing list does not conform to the equipment you received.

Storage and Transportation

**CAUTION**

- ◆ Store and transport this equipment based on the storage and transportation requirements for humidity and temperature.
- ◆ Avoid transporting the equipment in environments such as water splashing, rain, direct sunlight, strong electric field, strong magnetic field, and strong vibration.
- ◆ Avoid storing this equipment for more than three months. Long-term storage requires stricter protection and necessary inspections.
- ◆ Pack the equipment strictly before transportation. Use a sealed box for long-distance transportation.
- ◆ Never transport this equipment with other equipment or materials that may harm or have negative impacts on this equipment.

**WARNING**

- ◆ Use professional loading and unloading equipment to carry large-scale or heavy equipment.
- ◆ When carrying this equipment with bare hands, hold the equipment casing firmly with care to prevent parts falling. Failure to comply may result in personal injuries.
- ◆ Handle the equipment with care during transportation and mind your step to prevent personal injuries or equipment damage.
- ◆ Never stand or stay below the equipment when the equipment is lifted by hoisting equipment.

Installation

**WARNING**

- ◆ Thoroughly read the safety instructions and user guide before installation.
- ◆ Do not modify this equipment.
- ◆ Do not rotate the equipment components or loosen fixed bolts (especially those marked in red) on equipment components.
- ◆ Do not install this equipment in places with strong electric or magnetic fields.
- ◆ When this equipment is installed in a cabinet or final equipment, protection measures such as a fireproof enclosure, electrical enclosure, or mechanical enclosure must be provided. The IP rating must meet IEC standards and local laws and regulations.



DANGER

- ◆ Equipment installation, wiring, maintenance, inspection, or parts replacement must be performed by only professionals.
- ◆ Installation, wiring, maintenance, inspection, or parts replacement must be performed by only experienced personnel who have been trained with necessary electrical information.
- ◆ Installation personnel must be familiar with equipment installation requirements and relevant technical materials.
- ◆ Before installing equipment with strong electromagnetic interference, such as a transformer, install an electromagnetic shielding device for this equipment to prevent malfunctions.

Wiring



DANGER

- ◆ Equipment installation, wiring, maintenance, inspection, or parts replacement must be performed by only professionals.
- ◆ Never perform wiring at power-on. Failure to comply will result in an electric shock.
- ◆ Before wiring, cut off all equipment power supplies. Wait at least 10 minutes before further operations because residual voltage exists after power-off.
- ◆ Make sure that the equipment is well grounded. Failure to comply will result in an electric shock.
- ◆ During wiring, follow the proper electrostatic discharge (ESD) procedures, and wear an antistatic wrist strap. Failure to comply will result in damage to internal equipment circuits.



WARNING

- ◆ Never connect the power cable to output terminals of the equipment. Failure to comply may cause equipment damage or even a fire.
- ◆ When connecting a drive with the motor, make sure that the phase sequences of the drive and motor terminals are consistent to prevent reverse motor rotation.
- ◆ Wiring cables must meet diameter and shielding requirements. The shielding layer of the shielded cable must be reliably grounded at one end.
- ◆ After wiring, make sure that no screws are fallen and cables are exposed in the equipment.

Power-on

**DANGER**

- ◆ Before power-on, make sure that the equipment is installed properly with reliable wiring and the motor can be restarted.
- ◆ Before power-on, make sure that the power supply meets equipment requirements to prevent equipment damage or even a fire.
- ◆ At power-on, unexpected operations may be triggered on the equipment. Therefore, stay away from the equipment.
- ◆ After power-on, do not open the cabinet door and protective cover of the equipment. Failure to comply will result in an electric shock.
- ◆ Do not touch any wiring terminals at power-on. Failure to comply will result in an electric shock.
- ◆ Do not remove any part of the equipment at power-on. Failure to comply will result in an electric shock.

Operation

**DANGER**

- ◆ Do not touch any wiring terminals during operation. Failure to comply will result in an electric shock.
- ◆ Do not remove any part of the equipment during operation. Failure to comply will result in an electric shock.
- ◆ Do not touch the equipment shell, fan, or resistor for temperature detection. Failure to comply will result in heat injuries.
- ◆ Signal detection must be performed by only professionals during operation. Failure to comply will result in personal injuries or equipment damage.





**WARNING**

- ◆ Prevent metal or other objects from falling into the device during operation. Failure to comply may result in equipment damage.
- ◆ Do not start or stop the equipment using the contactor. Failure to comply may result in equipment damage.

Maintenance

**DANGER**

- ◆ Equipment installation, wiring, maintenance, inspection, or parts replacement must be performed by only professionals.
- ◆ Do not maintain the equipment at power-on. Failure to comply will result in an electric shock.
- ◆ Before maintenance, cut off all equipment power supplies and wait at least 10 minutes.

 WARNING <ul style="list-style-type: none">◆ Perform daily and periodic inspection and maintenance for the equipment according to maintenance requirements and keep a maintenance record.
Repair
 DANGER <ul style="list-style-type: none">◆ Equipment installation, wiring, maintenance, inspection, or parts replacement must be performed by only professionals.◆ Do not repair the equipment at power-on. Failure to comply will result in an electric shock.◆ Before inspection and repair, cut off all equipment power supplies and wait at least 10 minutes.
 WARNING <ul style="list-style-type: none">◆ Require repair services according to the product warranty agreement.◆ When the equipment is faulty or damaged, require professionals to perform troubleshooting and repair by following repair instructions and keep a repair record.◆ Replace quick-wear parts of the equipment according to the replacement guide.◆ Do not operate damaged equipment. Failure to comply may result in worse damage.◆ After the equipment is replaced, perform wiring inspection and parameter settings again.
Disposal
 WARNING <ul style="list-style-type: none">◆ Dispose of retired equipment by following local regulations or standards. Failure to comply may result in property damage, personal injuries, or even death.◆ Recycle retired equipment by following industry waste disposal standards to avoid environmental pollution.

Safety Signs

- Description of safety signs in the user guide



Read the user guide before installation and operation.



Reliably ground the system and equipment.



Danger!



High temperature!



Prevent personal injuries caused by machines.



High voltage!



Wait xx minutes before further operations.

- Description of safety signs on the equipment

For safe equipment operation and maintenance, comply with safety signs on the equipment, and do not damage or remove the safety labels. The following table describes the safety signs.

Safety Sign	Description
	<ul style="list-style-type: none"> ◆ Read the user guide before installation and operation. Failure to comply will result in an electric shock. ◆ Do not remove the cover at power-on or within 10 minutes after power-off. ◆ Before maintenance, inspection, and wiring, cut off input and output power, and wait at least 10 minutes until the power indicator is off.

Contents

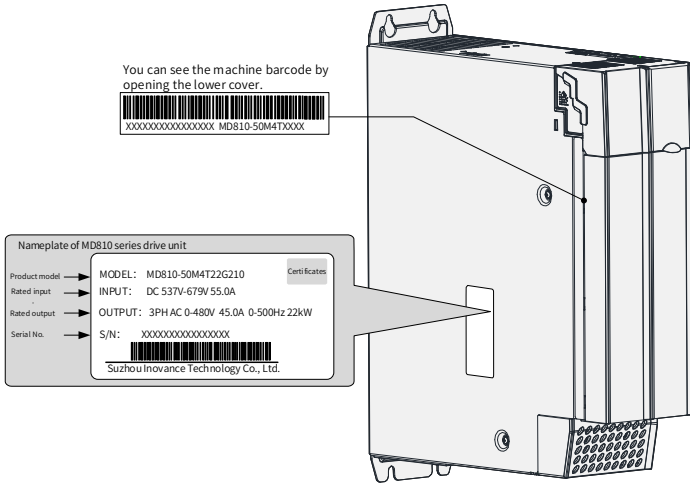
Preface	1
Revision History	3
Safety Instructions	4
Safety Precautions.....	4
Safety Levels and Definitions	4
Safety Instructions.....	4
Safety Signs.....	9
1 Product Information	12
1.1 Nameplate and Model Number	12
1.2 Components	13
1.3 Technical Data.....	13
1.4 System Structure	18
1.5 Selection of Electrical Peripherals.....	19
2 Installation.....	20
2.1 Cabinet Design.....	20
2.1.1 Clearance Requirements.....	20
2.1.2 Backplate Hole Size.....	22
2.2 Installation	23
2.2.1 Installation Methods	23
2.2.2 Installation of the Drive Unit.....	24
2.2.3 Cabinet Installation	29
2.2.4 Installation of the DC Soft Charge Unit.....	34
3 Wiring.....	38
3.1 Typical System Wiring	38
3.2 Main Circuit Wiring	38
3.2.1 Descriptions of Power Terminals	38
3.2.2 Recommended Cable of Power Terminals	39
3.3 Control Circuit Wiring	41
3.3.1 Descriptions of Control Terminals (Single-axis)	41
3.3.2 Descriptions of Control Terminals (Dual-axis).....	49
4 Panel Operations.....	54
4.1 Introduction	54
4.2 LED Operating Panel.....	54

4.2.1 Indicators	55
4.2.2 LED Display	56
4.2.3 Key Functions.....	56
4.2.4 Operation Procedure of the Three Levels of Menu	57
4.3 External LCD Operating Panel	58
4.3.1 Appearance and Display	58
5 Quick Commissioning.....	60
6 Troubleshooting.....	71
6.1 Fault Display and Solutions	71
6.2 Fault Codes and Solutions	72
6.3 Common Symptoms and Solutions	89
Appendix A Parameter Table	92
A.1 Basic Parameters.....	92
A.2 Monitoring Parameters	149
Warranty Agreement.....	152

1 Product Information

This chapter describes only the product information of the drive unit. For the product information of the power supply unit, see "810 Series Power Supply Unit User Guide".

1.1 Nameplate and Model Number



MD810 - 50M 4T D 45 G 0 0 0 W

Mark	Product Category
MD810	AC drive series
TD810	AC drive specialized for textile

Mark	Unit Type
20M	Power supply unit
50M	Drive unit

Mark	Voltage Class
4T	380-480V

Mark	Axis Type
Drive unit	None
	Single-axis
	D
	Dual-axis

Mark	Power Range (kW)
Power supply unit	22 22
	45 45
	110 110
	160 160
Drive unit	355 355
	1.5 1.5

	355 355

Mark	Model
G	General purpose

Mark	Heat Dissipation
None	1.5-160 kW (booksize unit)
H	90-355 kW (vertical tower unit)
W	11-30 kW (water cooling)

Mark	Optional Extension Part
0	None
1	1.5-160 kW (built-in STO)

Mark	Optional Communication Part	
Power supply unit	0	Built-in RS485 and CAN
	1	Built-in PROFIBUS-DP network bridge and CAN
	2	Built-in PROFINET network bridge and CAN (unavailable for the 35.5 kW model)
Drive unit	0	Built-in RS485 and CAN
	1	Built-in PROFIBUS-DP and CAN

Mark	Optional Functional Part	
Power supply unit	0	No optional built-in braking unit
	1	Built-in braking unit (only available for 22 kW and 45 kW models)
Drive unit	2	Built-in differential PG card
	3	Built-in 23-bit PG card
	4	Built-in resolver + frequency division card

Figure 1-1 Nameplate and product code of the drive unit



- ◆ The ProfiNet network bridge cannot be used for the 355 kW power supply unit.
- ◆ The water cooling models include the 160 kW power supply unit, 11 to 37 kW single-axis drive units, and dual-axis 7.5 to 18.5 kW drive units.
- ◆ Only the 22 kW and 45 kW power supply units are equipped with built-in braking units.

1.2 Components

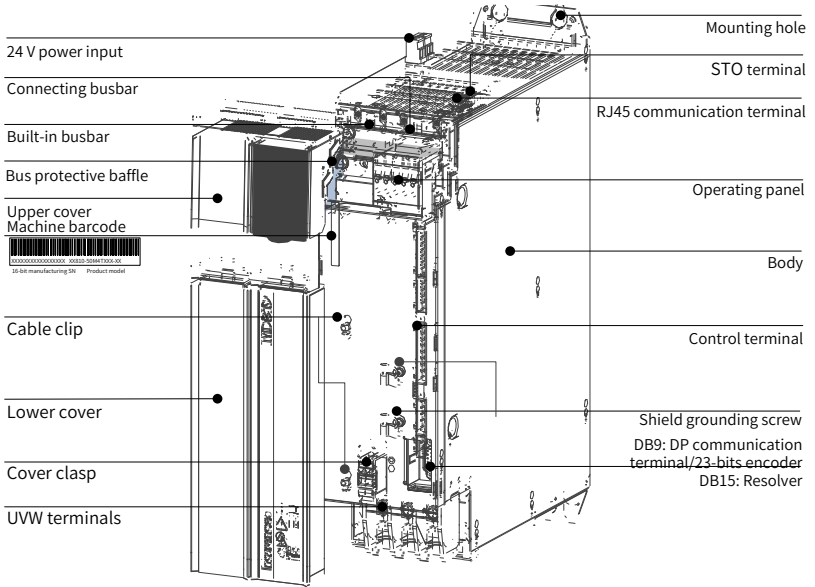


Figure 1-2 Components of the drive unit

1.3 Technical Data

Table 1-1 Technical data of the drive unit (single-axis, 1.5–75 kW)

Voltage Rating	380 VAC to 480 VAC															
Model: MD81050M4TxxxGxxx(W)	1.5	2.2	3.7	5.5	7.5	11	15	18.5	22	30	37	45	55	75		
Physical Dimensions	[H]: 350 mm [H1]: 384 mm [H2]: 400 mm [W]: 100 mm [W1]: 50 mm [D]: 305 mm					Air-cooling: [H]: 350 mm [H1]: 384 mm [H2]: 400 mm [W]: 100 mm [W1]: 50 mm [D]: 305 mm			Water-cooling: [H]: 350 mm [H1]: 384 mm [H2]: 415.5 mm [W]: 100 mm [W1]: 50 mm [D]: 305 mm			[H]: 350 mm [H1]: 384 mm [H2]: 400 mm [W]: 200 mm [W1]: 150 mm [D]: 305 mm				
Mounting Hole (mm)	Φ7															
Weight (kg)	3.8		4		7.5		8		8.5		9.4		18.4		19.5	

1 Product Information

Voltage Rating		380 VAC to 480 VAC													
Model: MD81050M4TxxxGxxx(W)		1.5	2.2	3.7	5.5	7.5	11	15	18.5	22	30	37	45	55	75
Input	Input Voltage	Three-phase 537 VDC to 679 VDC													
	Input Current, DC (A)	4.9	7	12	17	22	31	40	46	55	73	90	105	129	172
Output	Output Current, AC (A)	3.8	5.1	9	13	17	25	32	37	45	60	75	91	112	150
	Carrier Frequency	V/F control: 0.8 kHz to 12 kHz SVC/FVC: 2 kHz to 10 kHz Automatically adjusted based on heatsink temperature													
	Output Voltage	0 VAC to 480 VAC													
	Output Frequency	V/F control: 0 Hz to 500 Hz SVC/FVC: 0 Hz to 500 Hz													
Applicable Motor	kW	1.5	2.2	3.7	5.5	7.5	11	15	18.5	22	30	37	45	55	75
	HP	2	3	5	7.5	10	15	20	25	30	40	50	60	70	100
Thermal Design	Thermal Design Power (W)	47	59	76	127	155	249	294	343	425	526	669	817	1033	1379
	Air Flow (CFM)	10	10	10	10	10	40	40	55	65	75	105	130	175	195
Overvoltage Category		OVCIII													
Pollution Degree		PD2													
IP Rating		IP20													

Table 1-2 Technical data of the drive unit (single-axis, 90–355 kW)

Voltage Class		380 VAC to 480 VAC											
Model: MD810-50M4TxxxGxxx(H)		90	110	132	160	90	110	132	160	200	250	315	355
Physical Dimensions (mm)		Booksize Unit				Vertical Tower Unit							
	[H]: 350 mm					[H]: 750 mm	[H]: 900 mm	[H]: 1395 mm					
	[H1]: 384 mm					[H1]: 730 mm	[H1]: 885 mm	[H1]: 1365 mm					
	[H2]: 400 mm					[H2]: 770 mm	[H2]: 920 mm	[W]: 230 mm					
	[W]: 300 mm					[W]: 180 mm	[W]: 180 mm	[W1]: 100 mm					
	[W1]: 150 mm					[W1]: 125 mm	[W1]: 125 mm	[W2]: 75 mm					
[D]: 305 mm					[D]: 441.5 mm	[D]: 466.5 mm	[D]: 633 mm						
Mounting Hole (mm)		Φ7				Φ8				Φ9			
Weight (kg)		24.2	24.2	25.2	25.2	35	35	45	45	100	100	100	100

Voltage Class		380 VAC to 480 VAC											
Model: MD810-50M4TxxxGxxx(H)		90	110	132	160	90	110	132	160	200	250	315	355
		Booksize Unit				Vertical Tower Unit							
Input	Input Voltage	537 VDC to 679 VDC											
	Input Current, DC (A)	205	245	290	335	205	245	290	335	420	515	650	725
Output	Output Current, AC (A)	184	224	262	304	184	224	262	304	377	465	585	650
	Carrier Frequency (kHz)	V/F control: 0.8 kHz to 6 kHz SVC/FVC: 2 kHz to 6 kHz Automatically adjusted based on heatsink temperature											
	Output Voltage	0 VAC to 480 VAC											
	Output Frequency	V/F control: 0 to 500 Hz; SVC/FVC: 0 to 500 Hz											
Applicable Motor	kW	90	110	132	160	90	110	132	160	200	250	315	355
	HP	125	150	180	220	125	150	180	220	270	330	420	475
Thermal Design	Thermal Design Power (W)	1457	1728	2135.12	2389.1	1435	1800	2178	2405	3342	5109	6143	7912
	Air Flow (CFM)	145	311	270	270	118	118	248	189	265	353	447	706
Overvoltage Category		OVCIII											
Pollution Degree		PD2											
IP Rating		IP20				IP00							

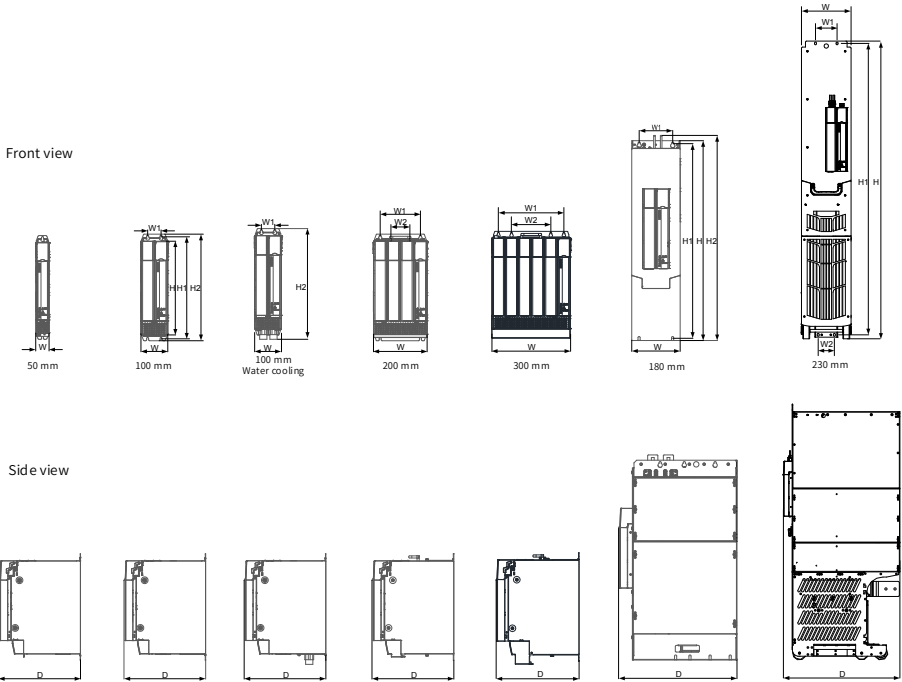


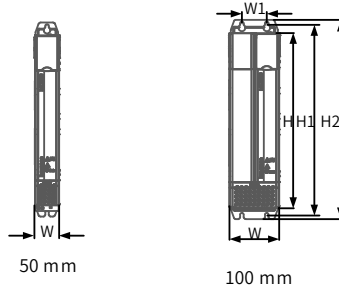
Figure 1-3 Overall dimensions of the drive unit (single-axis)

Table 1-3 Technical data of the drive unit (dual-axis)

Voltage Class		380 VAC to 480 VAC							
Model: MD810-50M4TDxxxGxxxW		1.5	2.2	3.7	5.5	7.5	11	15	18.5
Physical Dimensions (mm)		[H]: 350 mm [H1]: 384 mm [H2]: 400 mm		[W]: 50 mm [D]: 305 mm		[H]: 350 mm [H1]: 384 mm [H2]: 400 mm [W]: 100 mm		[W]: 100 mm [W1]: 50 mm [D]: 305 mm	
Mounting Hole (mm)		Φ7				Φ7			
Weight (kg)		4.5	4.5	4.5	4.5	6.5	9.5	9.5	9.5
Input	Input Voltage	Three-phase 537 VDC to 679 VDC							
	Input Current, DC (A)	10	14	24	34	44	62	80	92

Voltage Class		380 VAC to 480 VAC							
Output	Output Current, AC (A)	3.8	5.1	9	13	17	25	32	37
	Carrier Frequency	V/F control: 0.8 to 12 kHz SVC/FVC: 2 to 10 kHz Automatically adjusted based on heatsink temperature							
	Output Voltage	0 VAC to 480 VAC							
	Output Frequency	V/F control: 0 to 500 Hz; SVC/FVC: 0 to 500 Hz							
Applicable Motor	kW	1.5	2.2	3.7	5.5	7.5	11	15	18.5
	HP	2	3	5	7.5	10	15	20	25
Thermal Design	Thermal design power (W)	90	115	150	252	307	482	573	672
	Air Flow (CFM)	11	11	11	16	21	39	37	104
Overvoltage Category		OVCIII							
Pollution Degree		PD2							
IP Rating		IP20							

Front view



Side view

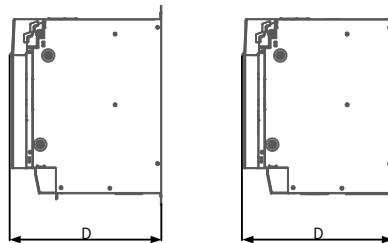


Figure 1-4 Overall dimensions of the drive unit (dual-axis)

1.4 System Structure

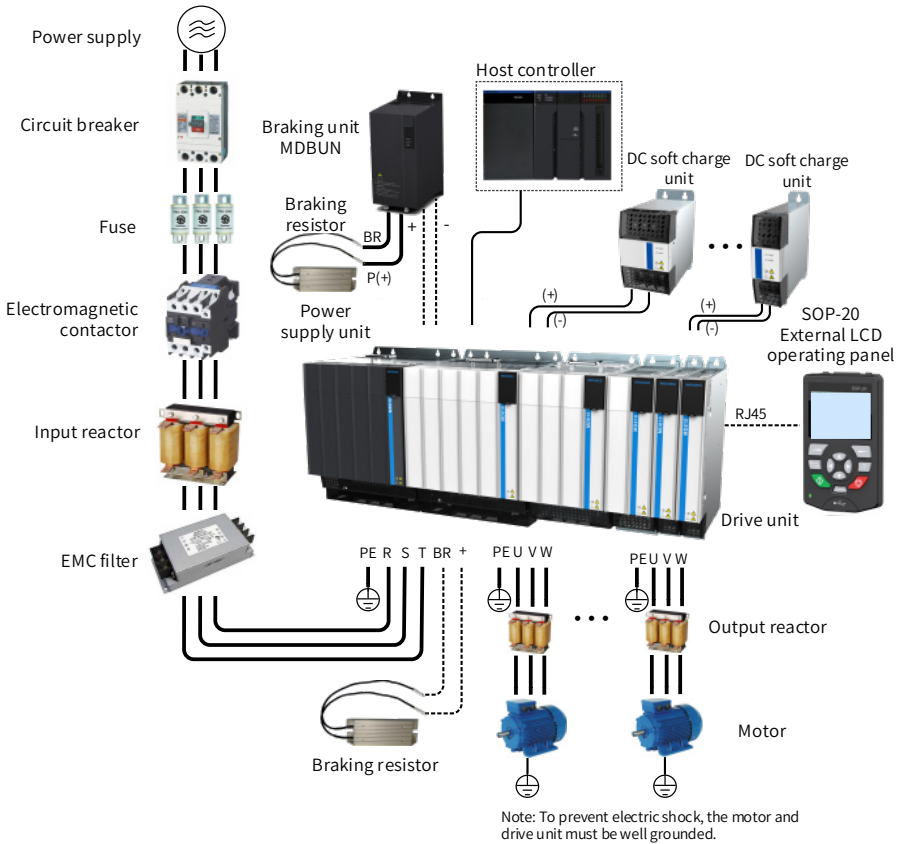


Figure 1-5 System structure



◆ For the detailed introduction of the power supply unit, see "810 Series Power Supply Unit User Guide".

1.5 Selection of Electrical Peripherals

Table 1-4 Selection of electrical peripherals for the MD810 AC drive

Product Model	Bus Fuse Bussmann (Passed UL Certification)		DC Soft Charge Unit Model	DC Circuit Breaker ABB (Passed UL Certification)	AC Output Reactor Model (Inovance)	dV/dt Reactor Model
	Model	QTY.				
MD810-50M4T1.5GXXX	FWC-16A10F	1	INOV-SU-30	S804S-UCK40	MD-OCL-5-1.4-4T-1%	RWK 305-4-KL
MD810-50M4T2.2GXXX	FWC-20A10F	1			MD-OCL-7-1.0-4T-1%	RWK 305-7.8-KL
MD810-50M4T3.7GXXX	FWC-16A10F	2			MD-OCL-10-0.7-4T-1%	RWK 305-10-KL
MD810-50M4T5.5GXXX	FWC-20A10F	2			MD-OCL-15-0.47-4T-1%	RWK 305-14-KL
MD810-50M4T7.5GXXX	FWC-25A10F	2			MD-OCL-20-0.35-4T-1%	RWK 305-17-KL
MD810-50M4T11GXXX	FWP-32A14Fa	2	INOV-SU-60	S804S-UCK80	MD-OCL-30-0.23-4T-1%	RWK 305-24-KL
MD810-50M4T15GXXX	FWP-40A14Fa	2			MD-OCL-40-0.18-4T-1%	RWK 305-32-KL
MD810-50M4T18.5GXXX	FWP-50A14Fa	2			MD-OCL-50-0.14-4T-1%	RWK 305-45-KL
MD810-50M4T22GXXX	170M1368	1			MD-OCL-60-0.12-4T-1%	RWK 305-45-KL
MD810-50M4T30GXXX	170M1369	1			MD-OCL-80-0.087-4T-1%	RWK 305-60-KL
MD810-50M4T37GXXX	170M1370	1	INOV-SU-100	S804S-UCK125	MD-OCL-90-0.078-4T-1%	RWK 305-72-KL
MD810-50M4T45GXXX	170M1371	1	INOV-SU-170	T4DCN250TMA 250FF3P	MD-OCL-120-0.058-4T-1%	RWK 305-90-KL
MD810-50M4T55GXXX	170M1372	1			MD-OCL-150-0.047-4T-1%	RWK 305-110-KL
MD810-50M4T75GXXX	170M1370	2			MD-OCL-200-0.035-4T-1%	RWK 305-156-KS
MD810-50M4T90GXXX	FWH-500A	1	HST-6004	-	MD-OCL-250-0.028-4T-1%	RWK 305-182-KS
MD810-50M4T110GXXX	FWH-600A	1			MD-OCL-250-0.028-4T-1%	RWK 305-230-KS
MD810-50M4T132GXXX	FWH-700A	1	HST-7004	-	MD-OCL-330-0.021-4T-1%	RWK 305-280-KS
MD810-50M4T160GXXX	FWH-800A	1	HST-7004	-	MD-OCL-330-0.021-4T-1%	RWK 305-330-KS
MD810-50M4T90GXXXH	170M4413	2	HST-6004	-	MD-OCL-250-0.028-4T-1%	RWK 305-182-KS
MD810-50M4T110GXXXH	170M4413	2			MD-OCL-250-0.028-4T-1%	RWK 305-230-KS
MD810-50M4T132GXXXH	170M4416	2	HST-7004	-	MD-OCL-330-0.021-4T-1%	RWK 305-280-KS
MD810-50M4T160GXXXH	170M4416	2			MD-OCL-330-0.021-4T-1%	RWK 305-330-KS
MD810-50M4T200GXXXH	170M6413	2	-	-	MD-OCL-490-0.014-4T-1%	RWK 305-400-S
MD810-50M4T250GXXXH	170M6415	2			MD-OCL-490-0.014-4T-1%	RWK 305-500-S
MD810-50M4T315GXXXH	170M6416	2			MD-OCL-660-0.011-4T-1%	RWK 305-600-S
MD810-50M4T355GXXXH	170M6418	2			MD-OCL-800-0.0087-4T-1%	RWK 305-680-S
MD810-50M4TD1.5GXXX	FWC-16A10F	2			INOV-SU-30	S804S-UCK40
MD810-50M4TD2.2GXXX	FWC-20A10F	2	MD-OCL-7-1.0-4T-1%	RWK 305-7.8-KL		
MD810-50M4TD3.7GXXX	FWC-25A10F	2	MD-OCL-10-0.7-4T-1%	RWK 305-10-KL		
MD810-50M4TD5.5GXXX	FWC-25A10F	2	MD-OCL-15-0.47-4T-1%	RWK 305-14-KL		
MD810-50M4TD7.5GXXX	FWC-32A10F	2	MD-OCL-20-0.35-4T-1%	RWK 305-17-KL		
MD810-50M4TD11GXXX	170M1368	1	INOV-SU-60	S804S-UCK80	MD-OCL-30-0.23-4T-1%	RWK 305-24-KL
MD810-50M4TD15GXXX	170M1369	1	INOV-SU-100	S804S-UCK125	MD-OCL-40-0.18-4T-1%	RWK 305-32-KL
MD810-50M4TD18.5GXXX	170M1370	1			MD-OCL-50-0.14-4T-1%	RWK 305-45-KL



NOTE

- ◆ For details about the electrical peripherals, see "MD810 Series Standard Drive (Multidrive System) Advanced User Guide".

2 Installation

This chapter describes only the mechanical installation of the drive unit. For the mechanical installation of the power supply unit, see "810 Series Power Supply Unit User Guide".

2.1 Cabinet Design

2.1.1 Clearance Requirements

The MD810 units comprise of:

- "Booksize format" with common height for power supply and drive units (different width: 50 mm, 100 mm, 200 mm, 300 mm)
- Larger rating power supply unit in "vertical tower format" whose dimensions (180 mm and 230 mm width) are larger than the booksize format

Single and dual rack installation is supported for the MD810 series drive unit. When installing two racks of booksize units, one above the other, as shown in Figure 2-1, observe the recommended air clearance distances between the top and bottom racks (see the following table for details) and install an air guide plate to allow for proper heat dissipation to avoid overheating the top rack.

Table 2-1 Minimum distance between units

Item	50 mm	100 mm	200 mm	300 mm	180 mm	230 mm
	Booksize				Vertical Tower	
S1	≥ 300 mm	≥ 300 mm	≥ 300 mm	≥ 300 mm	≥ 300 mm	≥ 300 mm
S2	≥ 300 mm	≥ 300 mm	≥ 300 mm	≥ 300 mm	≥ 500 mm	≥ 500 mm
S3	≥ 300 mm	≥ 300 mm	≥ 300 mm	≥ 300 mm	-	-

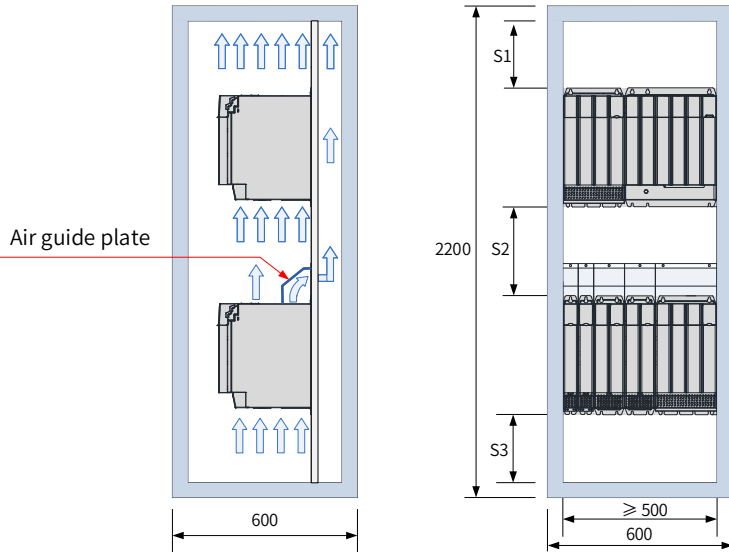


Figure 2-1 Clearance for booksize units in dual rack installation

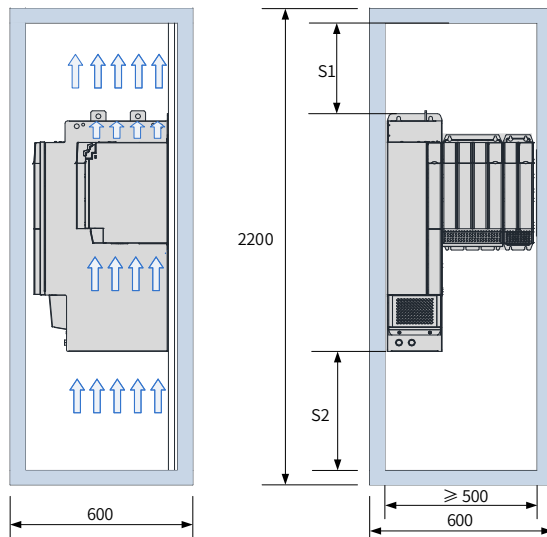


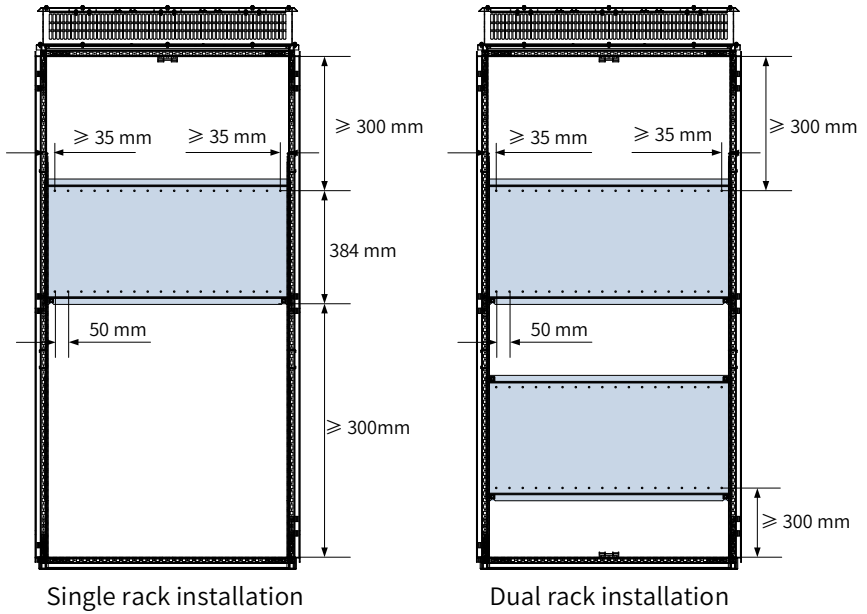
Figure 2-2 Heat dissipation clearances for the large power supply unit (vertical tower format)

**NOTE**

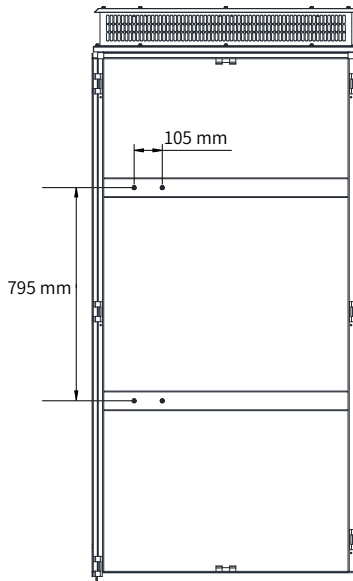
The vertical tower units are designed to be installed vertically to enable correct heat dissipation. Do not install horizontally.

2.1.2 Backplate Hole Size

- Dimensions of mounting holes for the booksize unit



- Dimensions of mounting holes for the vertical tower unit

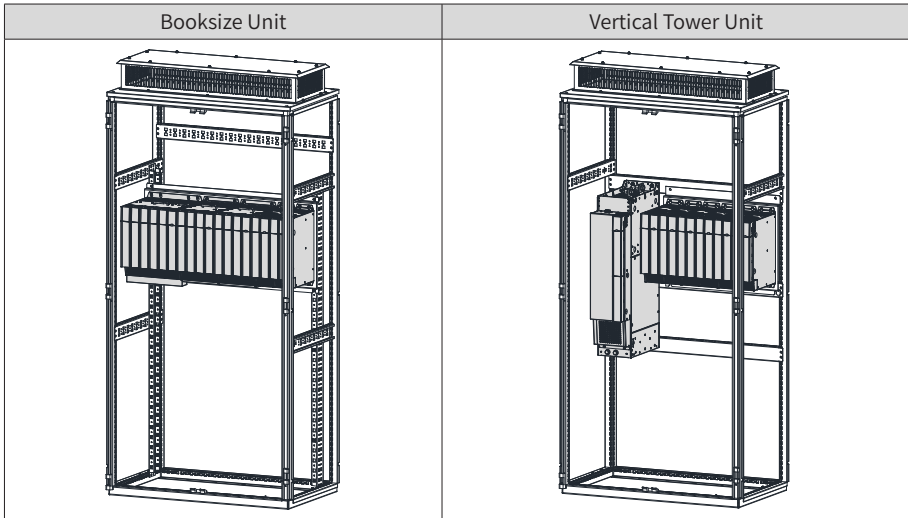


2.2 Installation

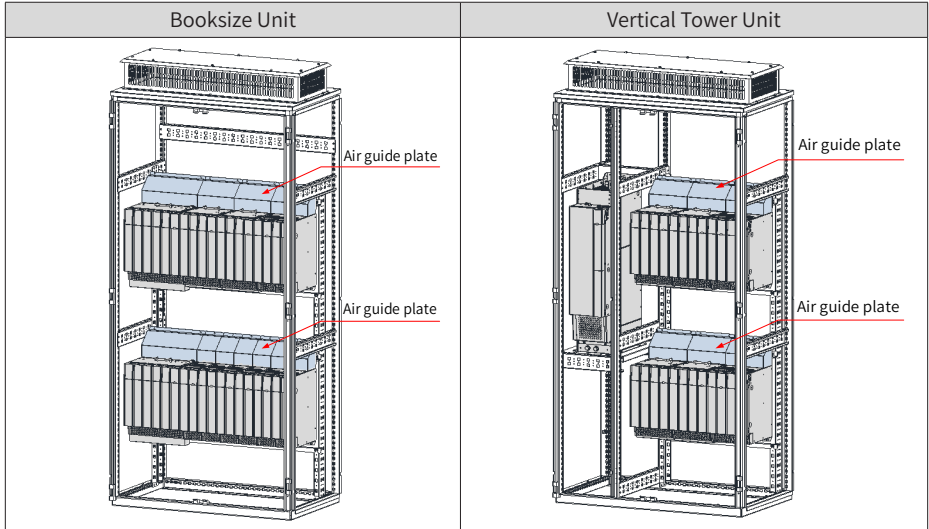
2.2.1 Installation Methods

The installation methods of this product in a cabinet support single rack installation and dual rack installation. The booksize unit must be installed in close arrangement to avoid damage to the power supply unit in transit. Do not install two or fewer drive units and even separately install them. The through-hole mounting method supports only single rack installation.

1) Single rack installation



2) Dual rack installation



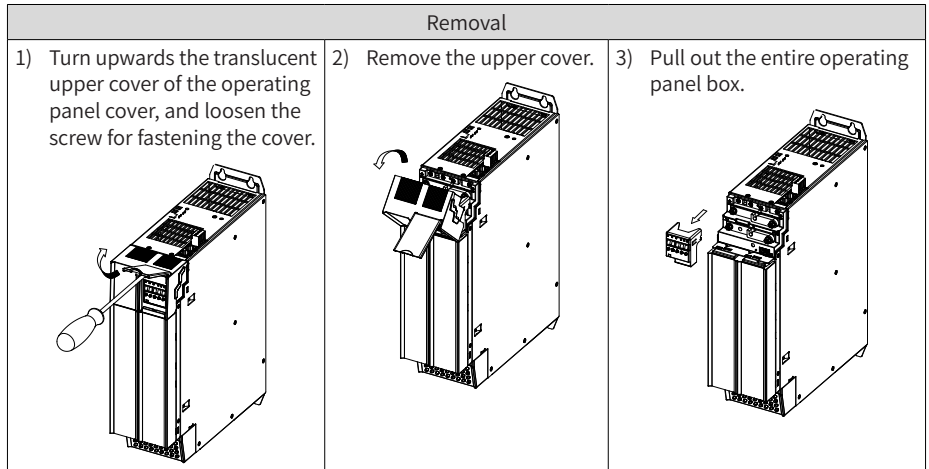
NOTE

- ◆ An insulation deflector may be selectively installed in the upper rack of units during dual rack installation.
- ◆ Do not separately install two or fewer drive units.
- ◆ The through-hole mounting method supports only single rack installation.

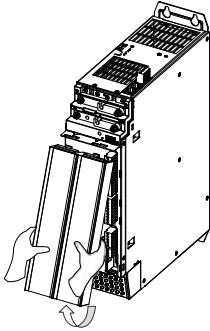
2.2.2 Installation of the Drive Unit

1 Removal and Refitting of Covers

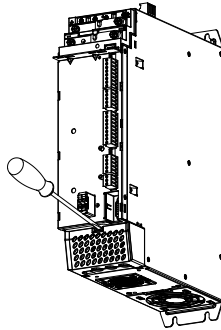
Remove and refit the covers according to the following procedure.



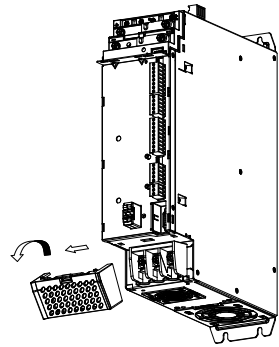
4) Hold the bottom of the lower cover and remove it.



5) Push inwards on the latch in the power terminal cover to release the cover.

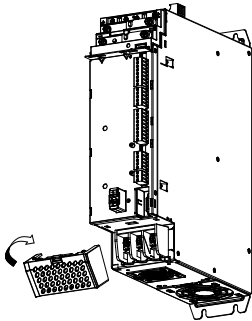


6) Remove the power terminal cover.

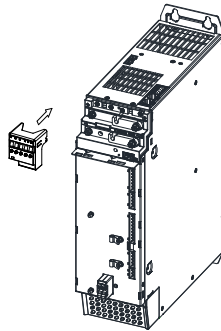


Refitting

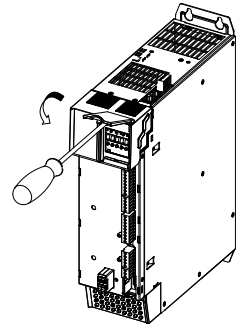
1) Locate the power terminal cover at its latch position, and fix it.



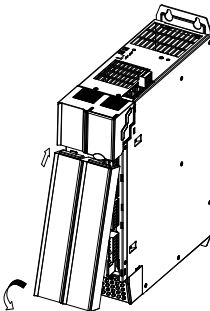
2) Install the operating panel.



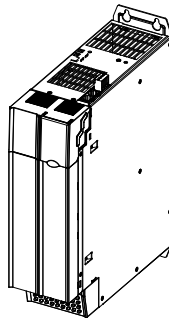
3) Locate the upper cover at its latch position and fix the cover, and fasten the screws.



4) Install the lower cover.

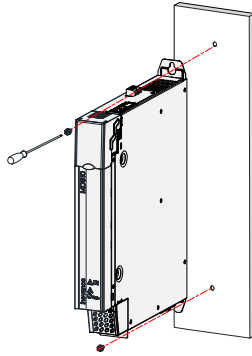


5) Installation is completed.

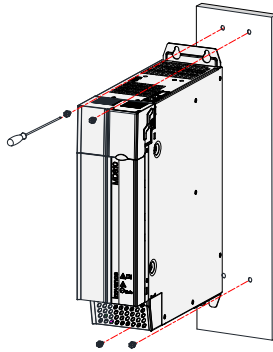


2 Backplate Mounting

- Backplate mounting of the booksize drive unit (50 mm wide)



- Backplate mounting of the booksize drive unit (100 mm wide)



- Backplate mounting of the booksize drive unit (200mm wide)

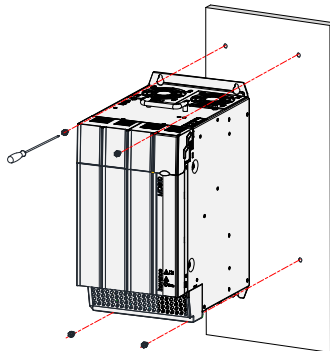


Figure 2-3 Backplate mounting of MD810-50M4T45G to MD810-50M4T75G

The mounting procedure is as follows:

- 1) Insert a screwdriver in the left and right clasps of the power terminal cover and push them up lightly to loosen the clasps.
 - 2) Turn downwards the terminal cover loosen from the clasps and remove it from the shell.
 - 3) Fabricate mounting holes shown in the figure on the mounting backplate. The M6 mounting nuts are used.
 - 4) Attach the unit to the mounting backplate with M6X15 screws and fix screws.
 - 5) Align the power terminal cover with the limit holes on the shell and press it lightly. If a click is heard, the installation is proper.
- Backplate mounting of the booksize drive unit (300 mm wide)

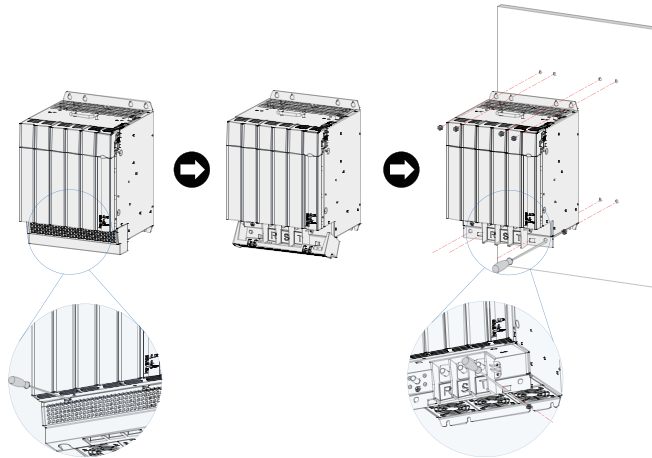


Figure 2-4 Backplate mounting of MD810-50M4T90G to MD810-50M4T160G

The mounting procedure is as follows:

- 1) Insert a screwdriver in the left and right clasps of the power terminal cover and push them up lightly to loosen the clasps.
- 2) Turn downwards the terminal cover loosen from the clasps and remove it from the shell.
- 3) Fabricate mounting holes shown in the figure on the mounting backplate. The M6 mounting nuts are used.
- 4) Attach the unit to the mounting backplate with M6X15 screws and fix screws.
- 5) Align the power terminal cover with the limit holes on the shell and press it lightly. If a click is heard, the installation is proper.



NOTE

◆ When fixing the two screws in the lower middle, insert the screwdriver through the holes of the clasp of the power terminals. The recommended Philips screwdriver model is slot 3# and rod length is greater than or equal to 190 mm.

- Backplate mounting of the vertical tower drive unit (180 mm wide)

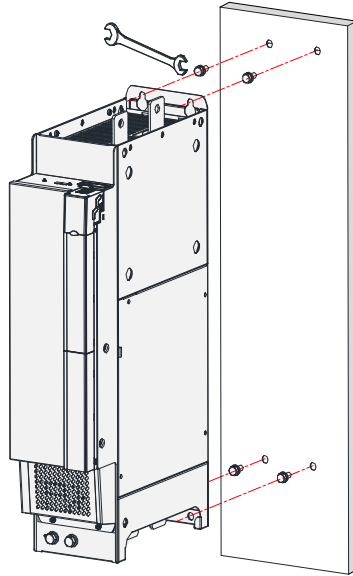


Figure 2-5 Backplate mounting of MD810-50M4T90G to MD810-50M4T160G

3 Through-hole mounting

- Through-hole mounting brackets

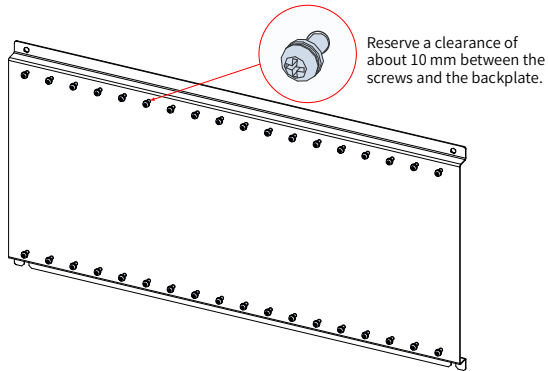


- 1 Upper and lower through-hole mounting brackets of 50 mm wide unit
- 2 Upper and lower through-hole mounting brackets of 100 mm wide unit
- 3 Upper and lower through-hole mounting brackets of 200 mm wide unit
- 4 Upper and lower through-hole mounting brackets of 300 mm wide unit

2.2.3 Cabinet Installation

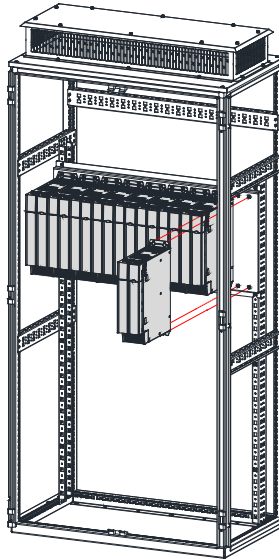
■ Cabinet Installation of the booksize unit

Step 1. Install screws in the backplate.



Step 2. Remove the covers.

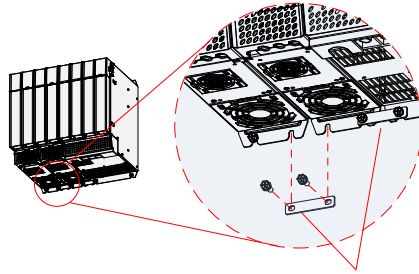
Step 3. Hang the units with the pre-installed screws.



Step 4. Install the EMC grounding aluminum bar.

To ensure proper grounding of the entire system (equipotential), install an aluminum bar between the mounting holes of two adjacent power supply unit and drive unit, and then install the units to the mounting surface. Note that every two adjacent units must

be connected with an aluminum grounding bar.

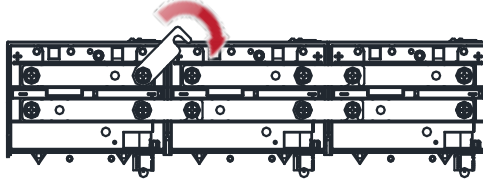


EMC grounding aluminum bar (delivered with the equipment), used to connect each unit

Step 5. Fasten the screws.

Step 6. Connect the built-in busbar. Loosen and turn over the busbar, and fasten the screws.

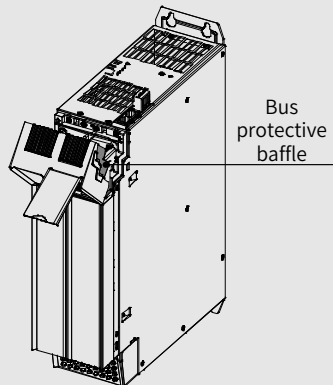
Turn over and connect



- ◆ Before connecting the built-in busbar, remove the left and right bus protective baffles in the top cover with tools such as nipper pliers/diagonal pliers. The following figure shows the position of the bus protective baffle.

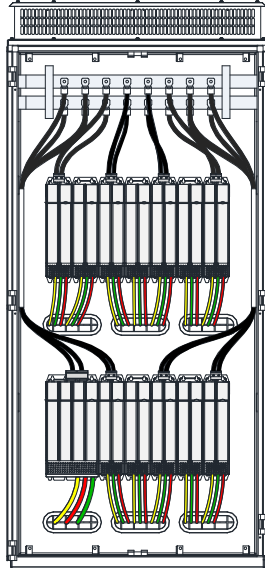


NOTE



- ◆ When a row of units are installed, the left bus protective baffle of the leftmost unit and the right bus protective baffle of the rightmost unit must be reserved to prevent electric shock.

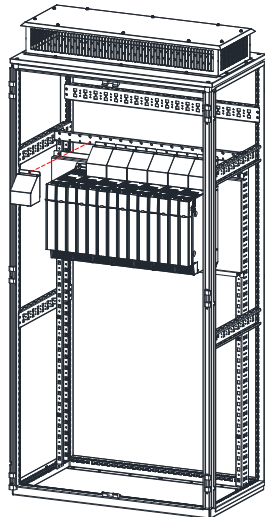
Step 7. Connect the busbar inside the cabinet, and wire the common bus power terminals.



Step 8. Connect cables to the control circuit terminals and PE cable.

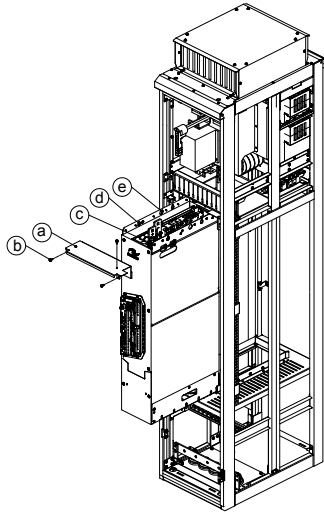
Step 9. Install the covers.

Step 10. Install the ventilation hood (option).



Step 11. Installation is completed.

■ Cabinet Installation of the vertical tower unit (90–160 kW)



Step 1. Hoist the drive unit into the cabinet by using the lifting holes (e) with hoisting equipment;

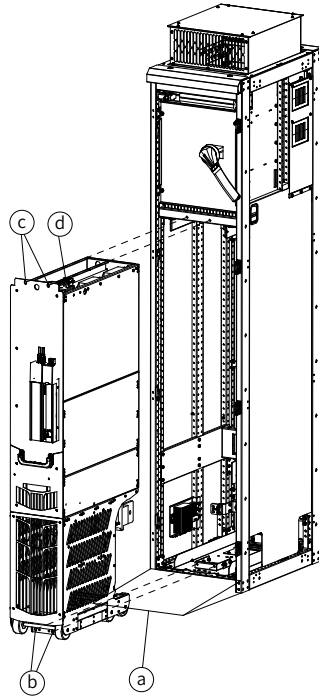
Step 2. Tighten the screw (d) to fix the drive unit;

Step 3. Install the terminal plug (c) for the external IO and control power supply;

Step 4. Connect all control cables. Put all the cables on one side and fasten them so that they are not in the way.

Step 5. Tighten the three screws (b) for the front air separator.

■ Cabinet Installation of the vertical tower unit (200–355 kW)



Step 1. Put a ramp (a) before the cabinet.

Step 2. Push the drive unit into the cabinet along the ramp.

Step 3. Tighten the fixing screws (b) and (c) for the drive unit.

Step 4. Connect all control cables (d) for the drive unit. Then, move the cables to one side and fix them.

2.2.4 Installation of the DC Soft Charge Unit

The following figure shows the diagram of using INOV-SU-30, INOV-SU-60, INOV-SU-100, INOV-SU-170 DC soft charge units in conjunction with the MD810 series drive unit.

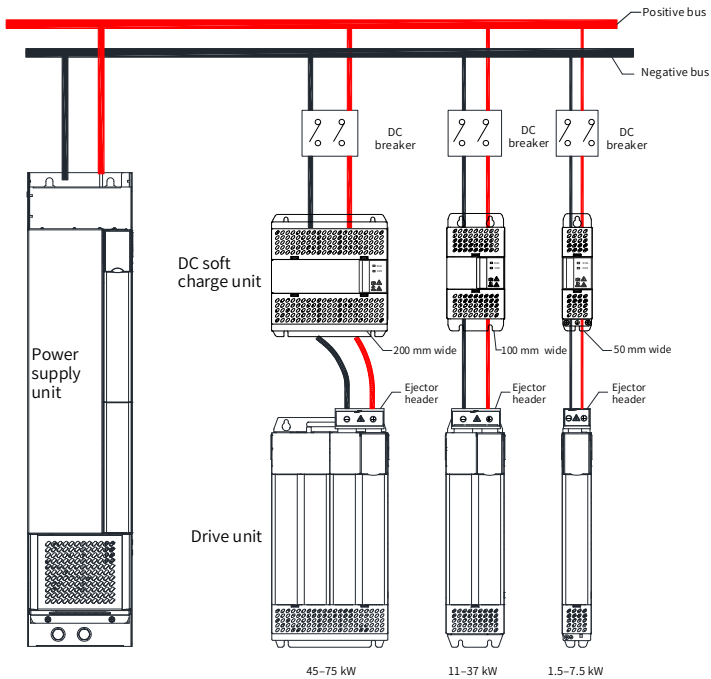


Figure 2-6 INOV-SU-30/INOV-SU-60/INOV-SU-100/INOV-SU-170 DC soft charge unit installation



NOTE

◆ Pay attention to the connection of the DC breaker in the preceding figure.

- HST-6004, HST-7004, and drive unit installation procedure (take HST-6004 as an example)
 - 1) As shown in figure a, remove the two M6 screws in the front side of HST-6004.
 - 2) Rotate the front side assembly upward, and then take it out as shown in figure b.
 - 3) Disassemble the HST-6004 functional assembly into two parts, figure c is the HST-6004 functional part, and figure d is the base.
 - 4) Connect the cable to the DC soft charge unit as shown in figure e.
 - 5) As shown in figure f, remove the four M4 screws on the top end of HST-6004.

- 6) As shown in figure g, fix the previous removed HST-6004 base on the corresponding four M4 holes. Figure h shows the completed look.
- 7) Reinstall the functional assembly onto the base of HST-6004, and connect the corresponding DC soft charge unit onto the model terminal, fix the terminal on the HST-6004 rear and the negative pole of H6 model terminal with M10*30 square neck bolt (BG14), flat washer, spring washer, and blot.

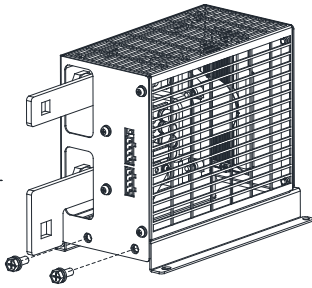


Figure a

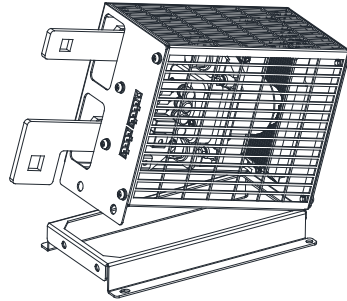


Figure b

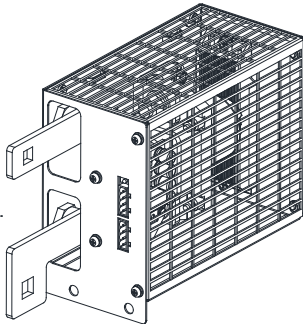


Figure c

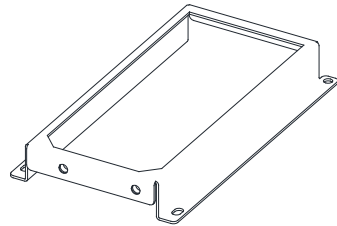


Figure d

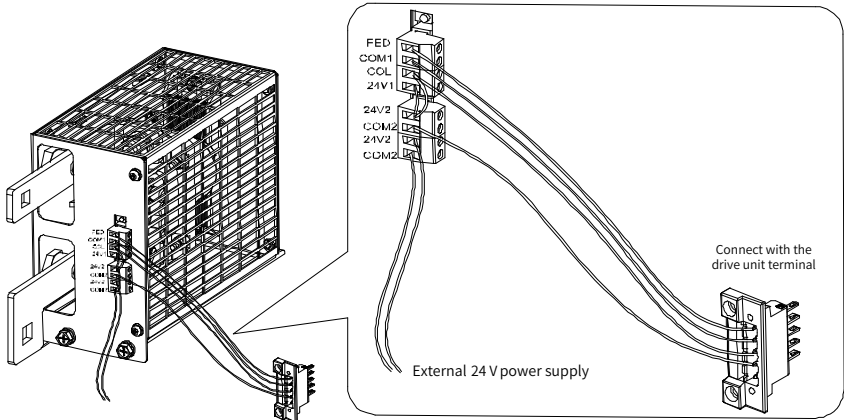


Figure e

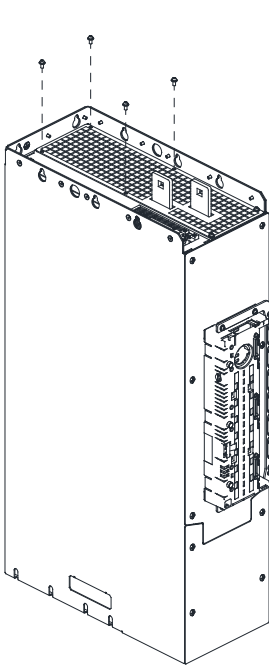


Figure f

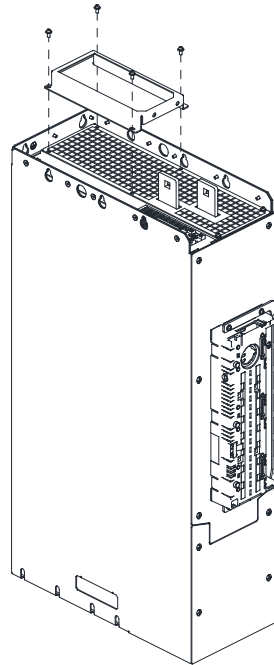


Figure g

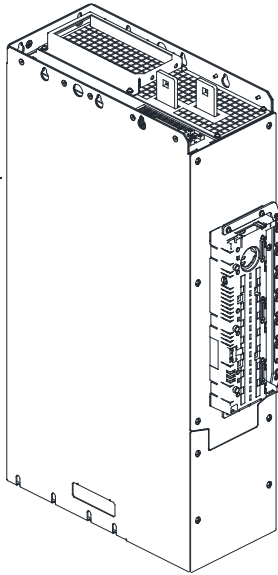


Figure h

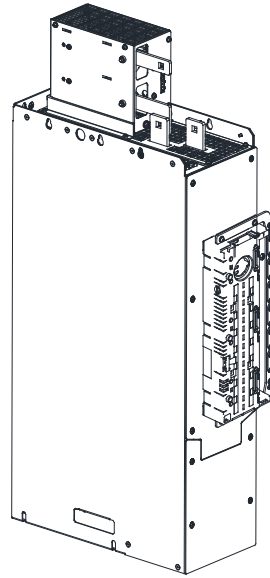


Figure i

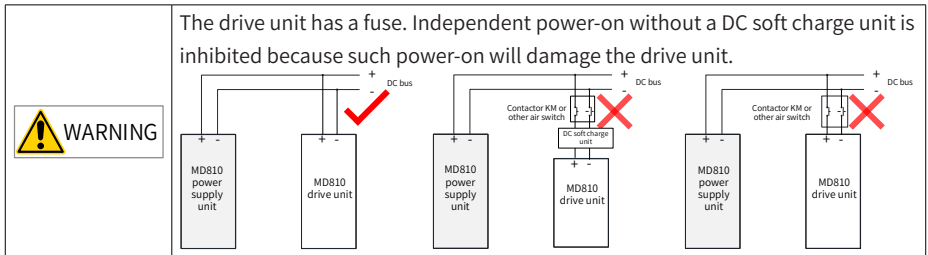
Figure 2-7 HST-6004/HST-7004 DC soft charge unit installation

3 Wiring

This chapter describes only the electrical installation of the drive unit. For the electrical installation of the power supply unit, see "810 Series Power Supply Unit User Guide".

3.1 Typical System Wiring

When using the MD810 at customer sites, if a drive unit fails and needs a replacement, the drive unit supports independent power-on and power-off without having to shut down the power supply unit. It is recommended to install a DC soft charge unit with each drive unit. For information of wiring, see Figure 3-6 which is on the last page of this chapter.



3.2 Main Circuit Wiring

3.2.1 Descriptions of Power Terminals

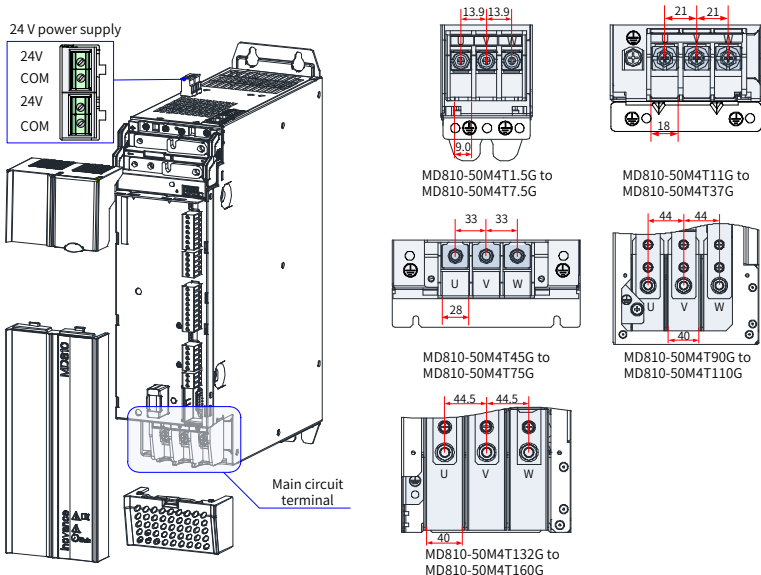


Figure 3-1 Power terminal arrangement and size of the drive unit (single-axis)

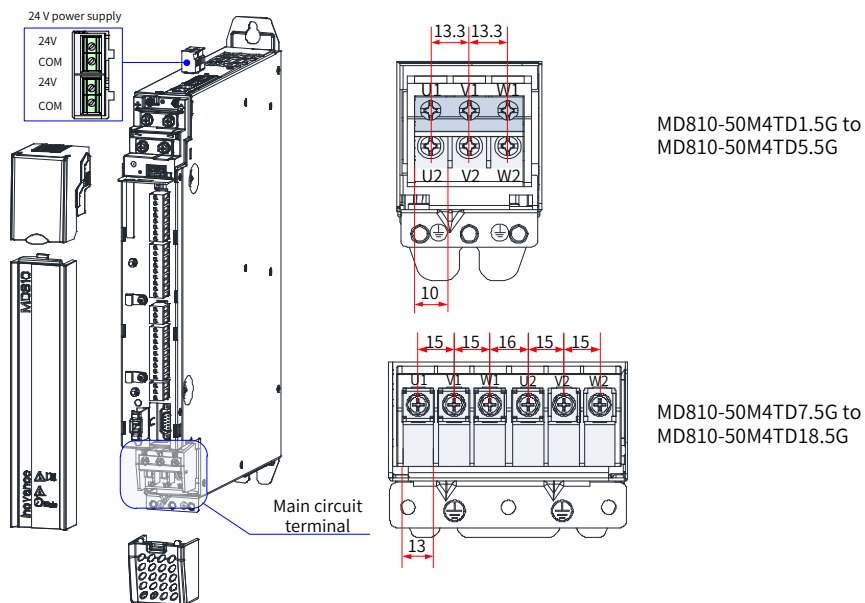


Figure 3-2 Power terminal arrangement and size of the drive unit (dual-axis)

Table 3-1 Descriptions of power terminals of the drive unit

Terminal Symbol	Terminal Function
P(+), (-)	DC bus terminals
U, V, W U1, V1, W1 U2, V2, W2	Three-phase AC output terminals
⊕	PE terminal

3.2.2 Recommended Cable of Power Terminals

Table 3-2 Recommended cable dimensions and tightening torque

Drive Unit Model	Output Terminal (U, V, W)			Ground Terminal (PE)		
	Output Cable (mm ²)	Screw Spec.	Tightening Torque (N·m)	Ground Cable (mm ²)	Screw Spec.	Tightening Torque (N·m)
MD810-50M4T1.5GXXX	0.75	M5	2.8	0.75	M5	2.8
MD810-50M4T2.2GXXX	0.75	M5	2.8	0.75	M5	2.8
MD810-50M4T3.7GXXX	1.0	M5	2.8	1.0	M5	2.8
MD810-50M4T5.5GXXX	1.5	M5	2.8	1.5	M5	2.8

Drive Unit Model	Output Terminal (U, V, W)			Ground Terminal (PE)		
	Output Cable (mm ²)	Screw Spec.	Tightening Torque (N·m)	Ground Cable (mm ²)	Screw Spec.	Tightening Torque (N·m)
MD810-50M4T7.5GXXX	2.5	M5	2.8	2.5	M5	2.8
MD810-50M4T11GXXX	4.0	M5	2.8	4.0	M6	4.8
MD810-50M4T15GXXX	6.0	M5	2.8	6.0	M6	4.8
MD810-50M4T18.5GXXX	10	M5	2.8	10	M6	4.8
MD810-50M4T22GXXX	10	M5	2.8	10	M6	4.8
MD810-50M4T30GXXX	16	M6	4.8	16	M6	4.8
MD810-50M4T37GXXX	25	M6	4.8	16	M6	4.8
MD810-50M4T45GXXX	35	M10	20.0	16	M10	20.0
MD810-50M4T55GXXX	50	M10	20.0	25	M10	20.0
MD810-50M4T75GXXX	70	M10	20.0	35	M10	20.0
MD810-50M4T90GXXX	95	M12	35.0	50	M10	20.0
MD810-50M4T110GXXX	120	M12	35.0	70	M10	20.0
MD810-50M4T132GXXX	150	M12	35.0	95	M10	20.0
MD810-50M4T160GXXX	185	M12	35.0	95	M10	20.0
MD810-50M4T90GXXXH	95	M10	20.0	50	M8	13.0
MD810-50M4T110GXXXH	120	M10	20.0	70	M8	13.0
MD810-50M4T132GXXXH	150	M10	20.0	95	M8	13.0
MD810-50M4T160GXXXH	185	M10	20.0	95	M8	13.0
MD810-50M4T200GXXXH	2*95	M12	35.0	95	M8	13.0
MD810-50M4T250GXXXH	2*120	M12	35.0	120	M8	13.0
MD810-50M4T315GXXXH	2*185	M12	35.0	185	M8	13.0
MD810-50M4T355GXXXH	2*185	M12	35.0	185	M8	13.0
MD810-50M4TD1.5GXXX	0.75	M5	2.8	0.75	M5	2.8
MD810-50M4TD2.2GXXX	0.75	M5	2.8	0.75	M5	2.8
MD810-50M4TD3.7GXXX	1.0	M5	2.8	1.0	M5	2.8
MD810-50M4TD5.5GXXX	1.5	M5	2.8	1.5	M5	2.8
MD810-50M4TD7.5GXXX	2.5	M5	2.8	2.5	M6	4.8
MD810-50M4TD11GXXX	4.0	M5	2.8	4.0	M6	4.8
MD810-50M4TD15GXXX	6.0	M5	2.8	6.0	M6	4.8
MD810-50M4TD18.5GXXX	10	M5	2.8	10	M6	4.8

3.3 Control Circuit Wiring

3.3.1 Descriptions of Control Terminals (Single-axis)

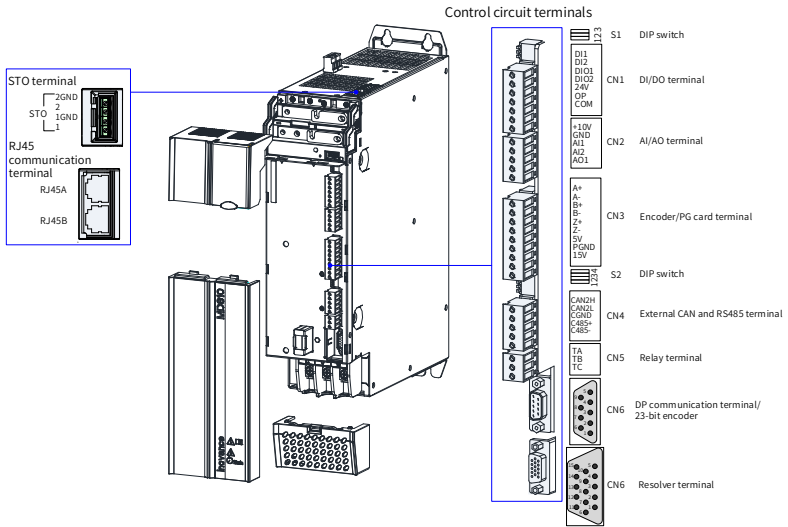


Figure 3-3 Control circuit terminal arrangement of the drive unit (single-axis 1.5–160 kW booksize unit)

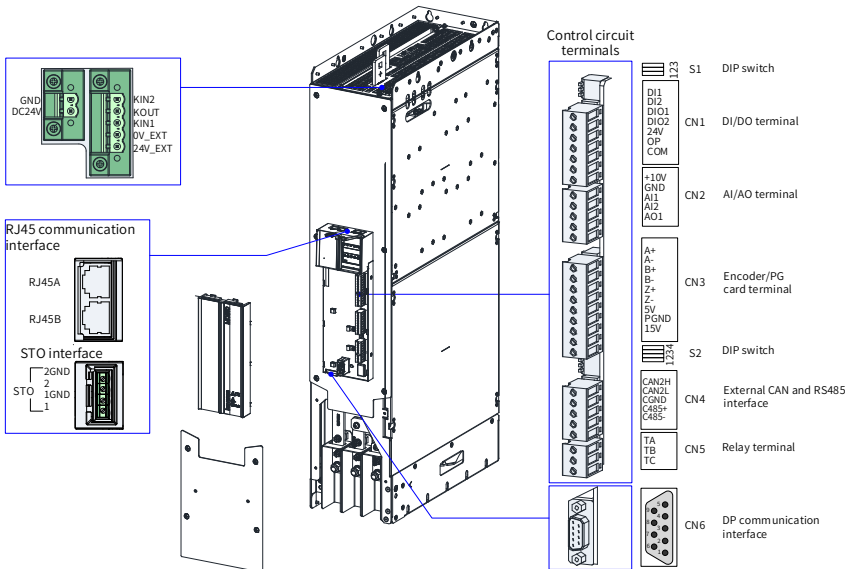


Figure 3-4 Control circuit terminal arrangement of the drive unit (single-axis 90–355 kW vertical tower unit)

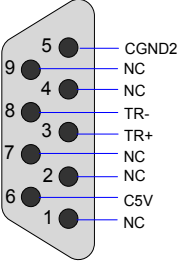
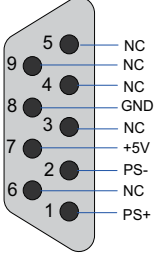
Table 3-3 Descriptions of control circuit terminals of the drive unit (single-axis)

Type	Terminal Symbol	Terminal Function	Performance
STO terminals	1	STO channel 1 power positive	24 V power supply
	1GND	STO channel 1 power negative	
	2	STO channel 2 power positive	
	2GND	STO channel 2 power negative	
External 24 V power terminal	DC24 V	External power 24 V power positive	External power 24 V power input for the internal control module with the minimum required current of 1 A
	GND	External power 24 V power negative	
Connect with the DC soft charge unit terminal	24 V_EXT	External DC soft charge unit external power supply positive	External power 24 V power input for the DC soft charge unit with the minimum required current of 1 A
	OV_EXT	External DC soft charge unit external power supply negative	
	KIN1	DI input	Receiving responses from the feedback module
	KOUT	DO output	Controlling the operation of relay and contactor
	KIN2	DI input	Reserved

Type	Terminal Symbol	Terminal Function	Performance
DI/DO terminals (CN1)	DI1-DI2	Ordinary multi-functional terminals	Programmable terminal for isolated sink/source input Input frequency < 100 Hz
	DIO1	High-speed pulse input terminal/Ordinary multi-functional output terminal	Programmable terminal for input or output When used as DI, maximum input frequency 100 kHz When used as DO, maximum output capacity 24 VDC, 50 mA
	DIO2	Ordinary multi-functional input terminal/High-speed pulse output terminal	Programmable terminal for input or output When used as DI, maximum input frequency < 100 Hz When used as DO, maximum output frequency 100 kHz, capacity 24 VDC, 50 mA
	OP	Multi-functional input/output common end	Internally isolated from COM and 24V. Shorted to 24 V using a U jumper by default
	24V	Internal 24 V	24V±10%, no-load voltage not more than 30 V Maximum output current of 200 mA Internally isolated from OP/CGND and GND
	COM	Internal 24 V ground	Internally isolated from CGND and GND

Type	Terminal Symbol	Terminal Function	Performance
AI/AO terminals (CN2)	AI1	Analog single-ended input channel 1	Programmable, 0 to 10 V or -10 to 10 V 12-bit resolution, correction accuracy 0.3%, input impedance 22.1 k Ω PT100/PT1000 temperature sensor (switchover by DIP switch S1)
	AI2	Analog single-ended input channel 2	Programmable, 0 to 10 V or 0 to 20 mA 12-bit resolution, correction accuracy 0.3% Input impedance: In voltage mode: 22.1 k Ω In current mode: 500 Ω or 250 Ω
	AO	Analog output	Programmable, 0 to 10 V or 0 to 20 mA 12-bit resolution, correction accuracy 0.5% In voltage mode, maximum output load current 2 mA, load impedance > 5 k Ω ; in current mode, load impedance < 500 Ω
	+10V	10 V analog voltage output	10 V \pm 10%, maximum 10 mA
	GND	Analog ground	Internally isolated from COM and CGND
Encoder/PG card terminal (CN3)	A+	Differential encoder A signal positive	Three types of encoders supported: Differential encoder, 5 V power supply OC encoder, 15 V power supply Push-pull encoder, 15 V power supply Switchover between 5 V and 15 V implemented by DIP switch 4 of S2 Note: CN3 is inactivated when CN6 is a 23-bit encoder interface
	A-	Differential encoder A signal negative/OC or push-pull encoder A signal	
	B+	Differential encoder B signal positive	
	B-	Differential encoder B signal negative/OC or push-pull encoder B signal	
	Z+	Differential encoder Z signal positive	
	Z-	Differential encoder Z signal negative/OC or push-pull encoder Z signal	
	5V	Encoder power supply	
	15V	Encoder power supply	
	PGND	Encoder power supply ground	

Type	Terminal Symbol	Terminal Function	Performance
RJ45A communication interface	CAN1H	CAN_H of communication signal	CANopen/CANlink supported
	CAN1L	CAN_L of communication signal	
	CGND	Ground of communication signals	
	RS485+	RS485 communication signal positive	RS485 internal bus
	RS485-	RS485 communication signal negative	
	Unconnected	/	
	Unconnected	/	
CGND	Ground of communication signals		
RJ45B communication interface	CAN1H	CAN_H of communication signal	CANopen/CANlink supported
	CAN1L	CAN_L of communication signal	
	CGND	Ground of communication signals	
	RS485+	RS485 communication signal positive	RS485 internal bus, used for the external LCD operating panel and PC commissioning
	RS485-	RS485 communication signal negative	
	C7V	Power supply to the external LCD operating panel	Power supply to the external LCD operating panel
	C7V	Power supply to the external LCD operating panel	
	CGND	Ground of communication signals	Ground of communication signals
CAN communication for synchronization control	CAN2H	CAN_H of CAN communication signal	
	CAN2L	CAN_L of CAN communication signal	
	CGND	Ground of CAN communication signal	
Relay terminal (CN5)	TA/TB/TC	TA-TB: NC TA-TC: NO	Contact capacity: 250 VAC/3 A ($\text{COS}\phi = 0.4$)

Type	Terminal Symbol	Terminal Function	Performance
DP communication interface (CN6)	Unconnected	/	
	Unconnected	/	
	TR+	DP bus positive	
	Unconnected	/	
	CGND2	Ground of DP bus power supply	
	C5V	DP bus power supply	
	Unconnected	/	
	TR-	DP bus negative	
	Unconnected	/	
23-bit encoder interface (CN6)	PS+	Bus communication signal+	
	PS-	Bus communication signal-	
	Unconnected	/	
	Unconnected	/	
	Unconnected	/	
	Unconnected	/	
	+5 V	Encoder +5 V power supply	
	GND	Encoder +5 V power supply ground	
	Unconnected	/	

Note: CN3 is invalid when CN6 is a 23-bit encoder interface

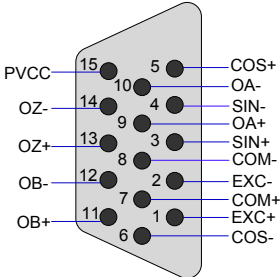




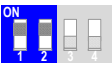
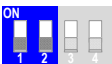
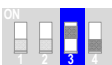
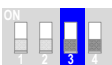


Type	Terminal Symbol	Terminal Function	Performance
Resolver interface (CN6)	EXC+	Excitation output signal+	 <p>The diagram shows a 15-pin connector with the following connections:</p> <ul style="list-style-type: none"> Pin 15: PVCC Pin 14: OZ- Pin 13: OZ+ Pin 12: OB- Pin 11: OB+ Pin 10: OA- Pin 9: OA+ Pin 8: COM- Pin 7: COM+ Pin 6: COS- Pin 5: COS+ Pin 4: SIN- Pin 3: SIN+ Pin 2: EXC- Pin 1: EXC+
	EXC-	Excitation output signal-	
	SIN+	Feedback sine signal+	
	SIN-	Feedback sine signal-	
	COS+	Feedback cosine signal+	
	COS-	Feedback cosine signal-	
	COM	Frequency division circuit power supply working ground	
	COM	Frequency division circuit power supply working ground	
	OA+	Frequency division output signal A+	
	OA-	Frequency division output signal A-	
	OB+	Frequency division output signal B+	
	OB-	Frequency division output signal B-	
	OZ+	Frequency division output signal Z+	
	OZ-	Frequency division output signal Z-	
PVCC	Frequency division circuit power supply (5-30 V)		

Table 3-4 Definition of DIP switches (single-axis)

Terminal Symbol	Terminal Name	Function Description	DIP Switch Position
S1	CAN1 termination resistor selection	Connect the termination resistor when switches 1 and 2 are turned on.	
		Connect no termination resistor when switches 1 and 2 are turned off.	
	AI1 function selection	PT100/PT1000 temperature detection when switch 3 is turned on.	
		Analog input when switch 3 is turned off.	
S2	C485 termination resistor selection	Connect the termination resistor when switches 1 and 2 are turned on.	
		Connect no termination resistor when switches 1 and 2 are turned off.	
	CAN2 termination resistor selection	Connect the termination resistor when switch 3 is turned on.	
		Connect no termination resistor when switch 3 is turned off.	
	PG interface 5 V and 15 V power supply selection	5 V power supply when switch 4 is turned on.	
		15 V power supply when switch 4 is turned off.	

3.3.2 Descriptions of Control Terminals (Dual-axis)

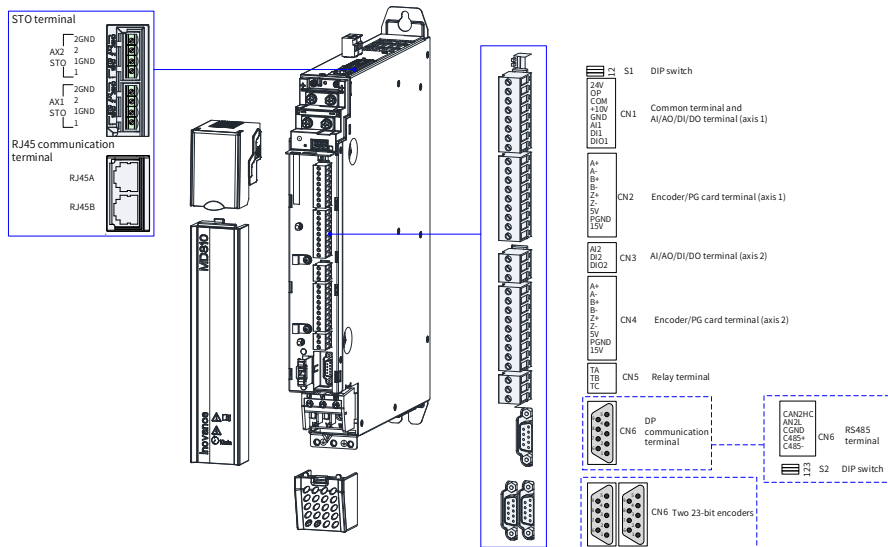


Figure 3-5 Control circuit terminal arrangement of the drive unit (dual-axis)

Table 3-5 Descriptions of control circuit terminals of the drive unit (dual-axis)

Type	Terminal Symbol	Terminal Function	Performance
STO terminals	1	STO channel 1 power positive	24 V power supply
	1GND	STO channel 1 power negative	
	2	STO channel 2 power positive	
	2GND	STO channel 2 power negative	

Type	Terminal Symbol	Terminal Function	Performance
DI/DO terminals	DI1	Ordinary multi-functional terminals	Programmable terminal for isolated sink/source input, Input frequency < 100 Hz
	DIO1	High-speed pulse input terminal/Ordinary multi-functional output terminal	Programmable terminal for input or output When used as DI, maximum input frequency 100 kHz When used as DO, maximum output capacity 24 VDC, 50 mA
	OP	Multi-functional input common terminal	Internally isolated from COM and 24V. Shorted to 24 V using a U jumper by default
	24V	Internal 24 V	24V±10%, no-load voltage not more than 30 V Maximum output current of 200 mA Internally isolated from OP/CGND and GND
	COM	Internal 24 V ground	Internally isolated from CGND and GND
AI terminals	AI1	AI1 analog single-ended input channel 1	Programmable, 0 to 10 V / -10 to 10 V / 0 to 20 mA, 12-bit resolution, correction accuracy 0.3%, input impedance 22.1 kΩ at voltage mode, input impedance 250 Ω or 500 Ω at current mode. PT100/PT100 temperature sensor (by F9-56)
	+10V	10 V analog voltage output	10 V±10%, maximum 10 mA
	GND	Analog ground	Internally isolated from COM and CGND

Type	Terminal Symbol	Terminal Function	Performance
Encoder/PG card terminal	A+	Differential encoder A signal positive	Three types of encoders supported: Differential encoder, 5 V power supply OC encoder, 15 V power supply Push-pull encoder, 15 V power supply Switchover between 5 V and 15 V implemented by F1-25 (Encoder power supply selection)
	A-	Differential encoder A signal negative/OC or push-pull encoder A signal	
	B+	Differential encoder B signal positive	
	B-	Differential encoder B signal negative/OC or push-pull encoder B signal	
	Z+	Differential encoder Z signal positive	
	Z-	Differential encoder Z signal negative/OC or push-pull encoder Z signal	
	5V	Encoder power supply	
	15V	Encoder power supply	
RJ45A communication interface	PGND	Encoder power supply ground	
	CAN1H	CAN_H of communication signal	CANopen/CANlink supported
	CAN1L	CAN_L of communication signal	
	CGND	Ground of communication signals	
	RS485+	RS485 communication signal positive	RS485 internal bus, used for the external LCD operating panel and PC commissioning
	RS485-	RS485 communication signal negative	
	Unconnected	/	
	Unconnected	/	
CGND	Ground of communication signals		

Type	Terminal Symbol	Terminal Function	Performance
RJ45B communication interface	CAN1H	CAN_H of communication signal	CANopen/CANlink supported
	CAN1L	CAN_L of communication signal	
	CGND	Ground of communication signals	
	RS485+	RS485 communication signal positive	RS485 internal bus, used for the external LCD operating panel and PC commissioning
	RS485-	RS485 communication signal negative	
	C7V	Power supply to the external LCD operating panel	Power supply to the external LCD operating panel
	C7V	Power supply to the external LCD operating panel	
	CGND	Ground of communication signals	Ground of communication signals
CAN communication for synchronization control	CAN2H	CAN_H of CAN communication signal	
	CAN2L	CAN_L of CAN communication signal	
	CGND	Ground of CAN communication signal	
Relay terminal	TA/TB/TC	TA-TB: NC TA-TC: NO Axis 1 and axis 2 are shared.	Contact capacity: 250 VAC/3 A ($\text{COS}\phi = 0.4$)
DP communication interface (CN6)	Unconnected	/	
	Unconnected	/	
	TR+	DP bus positive	
	Unconnected	/	
	CGND2	Ground of DP bus power supply	
	C5V	DP bus power supply	
	Unconnected	/	
	TR-	DP bus negative	

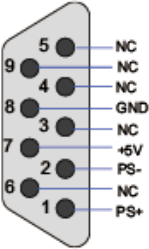


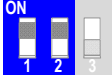

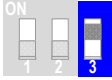
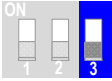
Type	Terminal Symbol	Terminal Function	Performance
23-bit encoder interface (CN6)	PS+	Bus communication signal+	 <p>Note: CN2 and NC4 are invalid when CN6 is a 23-bit encoder interface.</p>
	PS-	Bus communication signal-	
	Unconnected	/	
	Unconnected	/	
	Unconnected	/	
	Unconnected	/	
	+5 V	Encoder +5 V power supply	
	GND	Encoder +5 V power supply ground	
	Unconnected	/	

Table 3-6 Definition of DIP switches (dual-axis)

Terminal Symbol	Terminal Name	Function Description	DIP Switch Position
S1	CAN1 termination resistor selection	Connect the termination resistor when switches 1 and 2 are turned on.	
		Connect no termination resistor when switches 1 and 2 are turned off.	
S2	C485 termination resistor selection	Connect the termination resistor when switches 1 and 2 are turned on.	
		Connect no termination resistor when switches 1 and 2 are turned off.	
	CAN2 termination resistor selection	Connect the termination resistor when switch 3 is turned on.	
		Connect no termination resistor when switch 3 is turned off.	

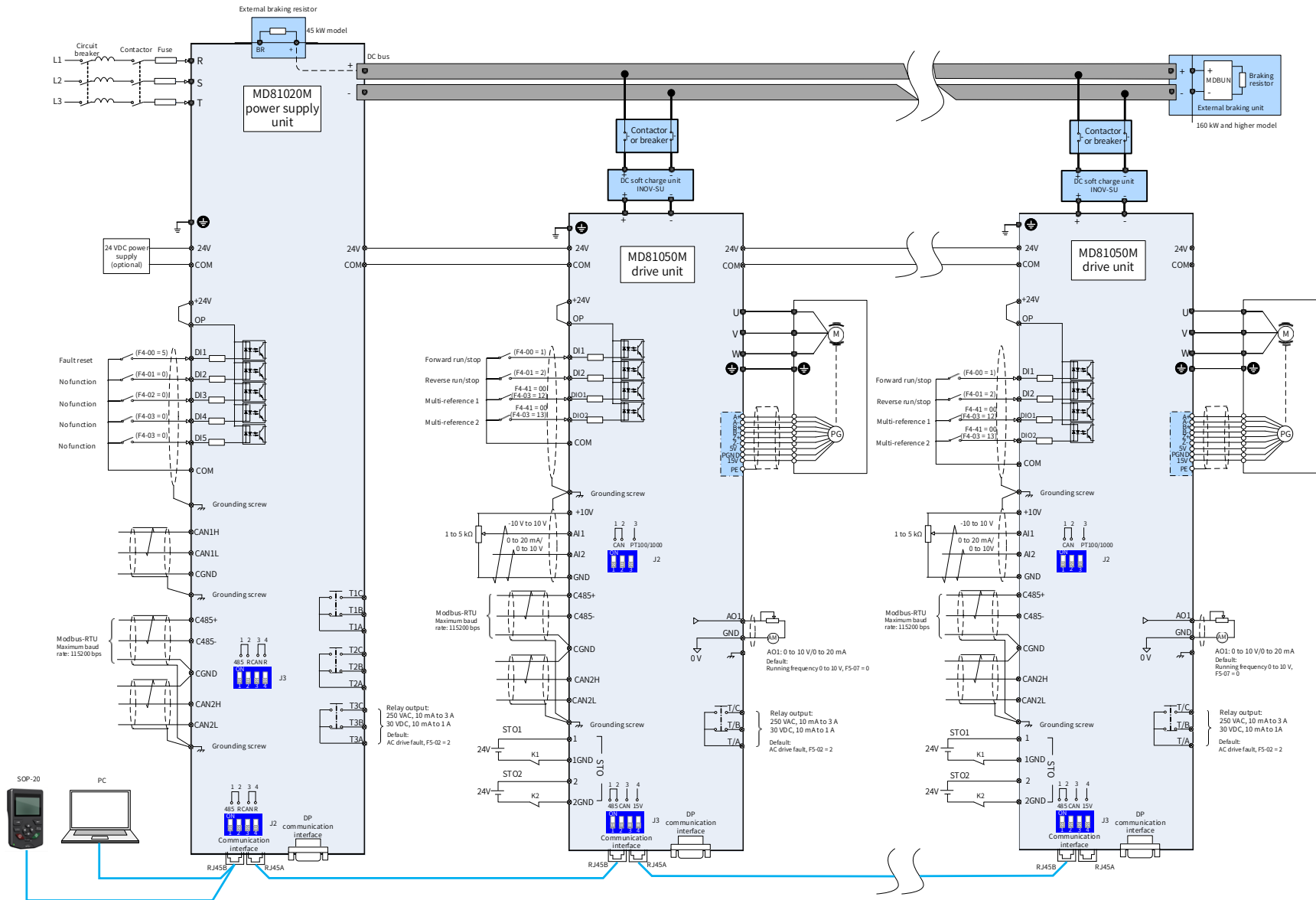


Figure 3-6 Typical system wiring diagram



WARNING

The drive unit has a fuse. Independent power-on without a DC soft charge unit is inhibited because such power-on will damage the drive unit.

4 Panel Operations

4.1 Introduction

The MD810 series AC drive enables you to work on parameters, monitor and control product status by LED operation and external LCD operating panel.

Besides the LED operating board delivered with the AC drive, customers can also configure an external LCD keyboard to achieve remote control. The LED operating panel supports parameter viewing and modification. the external LCD keyboard supports parameter copy, parameter uploading, parameter downloading, and running control (start and stop).

4.2 LED Operating Panel

The LED operating panel allows you to monitor system operation, modify parameters, and carry out motor auto-tuning. Appearance and keys of the operating panel are as follows:

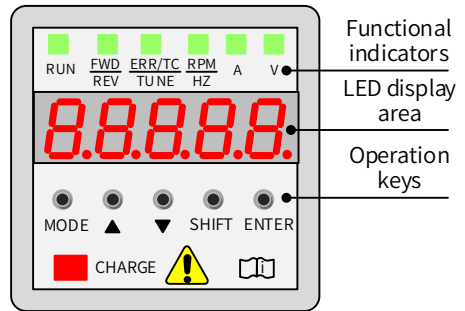
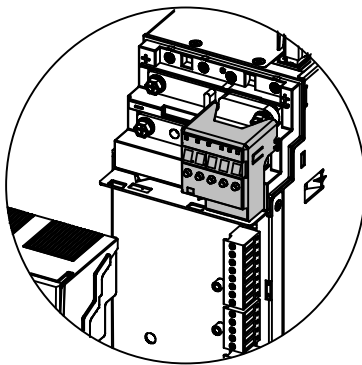


Figure A

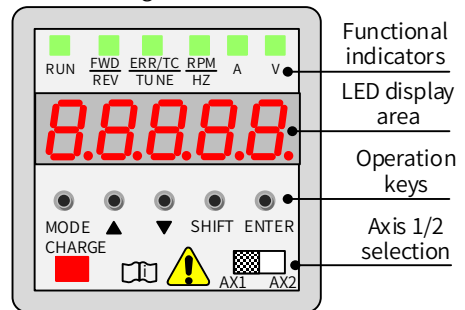


Figure B

Note:

Figure A shows the LED operating panel of the single-axis drive.

Figure B shows the LED operating panel of the dual-axis drive.

Figure 4-1 Appearance of the operating panel

4.2.1 Indicators
























In the following table,  in the following table indicates ON;  indicates OFF;  indicates flash.

Table 4-1 Description of status indicators

Indicator State		State Description
RUN indicator	 RUN	Off: Stop
	 RUN	On: Running
FWD/REV indicator	 FWD/REV	Off: Forward running
	 FWD/REV	On: Reverse running
ERR/TC/TUNE Fault/Torque control/ Auto-tuning indicator	 ERR/TC/TUNE	Off: Speed mode
	 ERR/TC/TUNE	ON (green): Torque control mode
	 ERR/TC/TUNE	Slow flash (green): Auto-tuning state (1 time/s)
	 ERR/TC/TUNE	Quick flash (red): fault state (4 times/s)
 RPM/Hz	 A  V	Speed/Frequency unit: RPM/Hz
 Hz	 A  V	Current unit: A
 Hz	 A  V	Voltage unit: V
 Hz	 A  V	Parameter unit: %

4.2.2 LED Display







There are 5-digit LEDs on the LED operating panel to display the set frequency, output frequency, various monitoring data, and alarm codes.

Table 4-2 LED display and actual data

LED Display	Actual Data	LED Display	Actual Data	LED Display	Actual Data	LED Display	Actual Data
0	0	7	7	d	D	o	o
1	1	8	8	E	E	P	P
2	2	9	9, g	F	F	r	R
3	3	A	A	H	H	f	T
4	4	b	B	J	J	U	U
5	5, S	C	C	L	L	u	u
6	6	c	c	N	N		



4.2.3 Key Functions

Table 4-3 Key function description

Key	Key Name	Function Description
 MODE	Programming	Enter or exit a menu, and perform parameter query mode switchover.
	Up	Data or parameter increment
	Down	Data or parameter decrement
 SHIFT	Shift	<ul style="list-style-type: none"> ◆ Select the displayed parameter in the STOP or RUNNING status. ◆ Select the digit to be modified when modifying a parameter value.
 ENTER	ENTER	<ul style="list-style-type: none"> ◆ Enter each level of menu interface. ◆ Confirm displayed parameter setting.
 AX1 AX2	AX1/AX2 selection	Select axis 1/2 as the main axis. By default, AX1 is selected.

4.2.4 Operation Procedure of the Three Levels of Menu

The LED operating panel of the MD810 drive uses a three-level menu structure to perform operations such as parameter settings. After entering a menu at every level,

press  and  to perform modification when a display bit flashes. The following figure shows the operation flow.

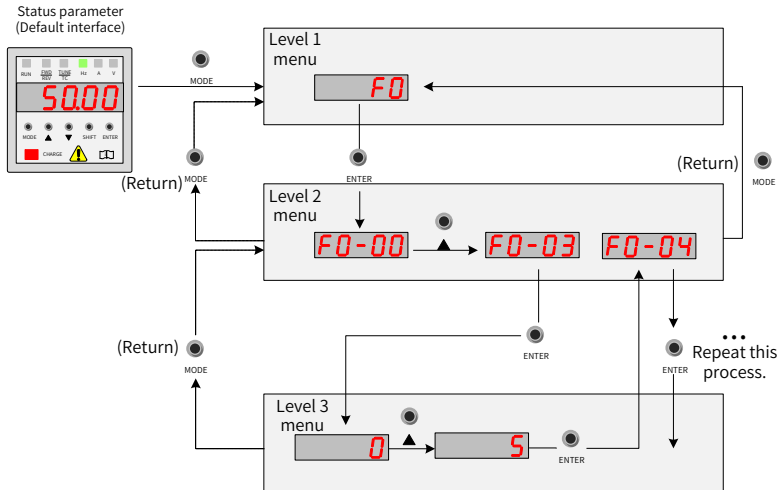


Figure 4-2 Operation flowchart for the 3-level menu structure

4.3 External LCD Operating Panel



The external LCD operating panel (SOP-20) provides the functions of parameter setting, status monitoring, parameter copying, fault analysis, and positioning, program downloading, USB relay and so on.

4.3.1 Appearance and Display



Figure 4-3 Appearance of external LCD operating panel

Name	Legend	Function Description
Left soft key		Used to execute the display function at the bottom left of the screen.
Right soft key		Used to execute the display function at the bottom right of the screen.
Toggle key		Used to quickly enter the equipment list page. In some pages where operations cannot be interrupted, the quick model toggle function is disabled and this key is invalid.
Arrow keys		The up and down arrow keys are used to select options in a display menu and list, scroll up and down a text page and adjust a value (e.g. setting time, entering a password or changing a parameter value). The left and right arrow keys are used to move the cursor left and right.
Help key		Used to open a help page. A help page depends on the context, i.e. the contents of this page are related to a corresponding menu or view. For more information about a help page, see "Help".
RUN key		Used to start up the drive in local control mode.

Name	Legend	Function Description
Stop key		Used to stop the drive in local control mode. When the equipment is faulty, the stop key is used to reset the equipment.
Loc/Rem toggle key		Used to switch control between the control panel (local) and the remote connection (remote).

Main interface display:

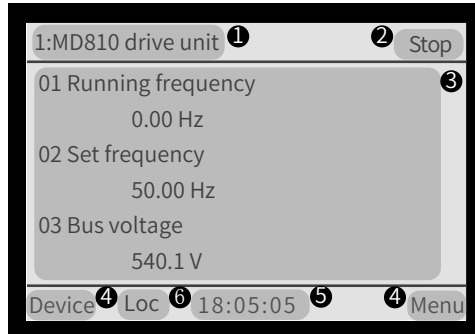


Figure 4-4 Main interface of the external LCD operating panel

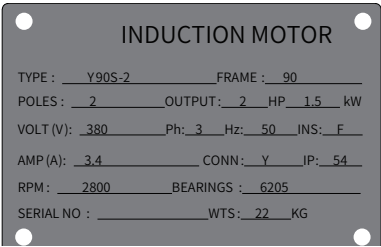
- ❶ Current equipment information: The value in the front is station No. The value in the rear is a specific equipment name.
- ❷ Equipment status and fault information: Displays the running status information of the current equipment. When the equipment fails, fault information is displayed by flashing and the running status is not displayed.
- ❸ Content area: Displays actual contents of a view in this area. Contents of every view are different. The preceding example view is a homepage.
- ❹ Soft key selection: Displays the soft key function in the given context.
- ❺ Clock: Displays the current time.
- ❻ Control position:

Loc: Local control by the external LCD operating panel is enabled.




Rem: Remote control by I/O or bus is enabled.

Blank: This function is unavailable on the equipment.

5 Quick Commissioning

Operation	Para. No.	Parameter Name	Default	Commission
START				
Before power on				
Install and wire the drive		Install and wire the units as explained in chapters 1 to 3.		
Check UVW wirings of power supply and drive units		-		
Restore parameters	FP-01	Parameter initialization	0	
		0: No operation 01: Restore factory parameters except motor parameters, encoder parameters, and F0-10 (Maximum frequency) 02: Clear records 04: Back up current user parameters 501: Restore backup user parameters 502: Restore to factory setting (except FD group and AF group parameters) (supported by only dual-axis models) NOTE: It is recommended to "Restore default settings" before commissioning the device.		
Set motor parameters		Motor Nameplate		
		 <p style="text-align: center;">INDUCTION MOTOR</p> <p>TYPE : <u>Y90S-2</u> FRAME : <u>90</u> POLES : <u>2</u> OUTPUT : <u>2</u> HP <u>1.5</u> kW VOLT (V) : <u>380</u> Ph: <u>3</u> Hz: <u>50</u> INS: <u>F</u> AMP (A) : <u>3.4</u> CONN: <u>Y</u> IP: <u>54</u> RPM : <u>2800</u> BEARINGS : <u>6205</u> SERIAL NO : _____ WTS: <u>22</u> KG</p>		
	F1-01	Rated motor power	Model dependent	
		Unit: kW		
	F1-02	Rated motor voltage	Model dependent	

Operation	Para. No.	Parameter Name	Default	Commission	
		Unit: V			
	F1-03	Rated motor current	Model dependent		
		Unit: A			
	F1-04	Rated motor frequency	Model dependent		
		Unit: Hz			
If an encoder is used	F1-05	Rated motor speed	Model dependent		
		Unit: RPM			
	Set encoder parameters	F1-27	Encoder pulses per revolution	1024	
			1 to 20,000PPR		
		F1-28	Encoder type	0	
		0: ABZ incremental encoder 1: 23-bit encoder 2: Resolver			
Perform motor auto-tuning	F1-30	A/B phase sequence of ABZ encoder	0		
		0: Positive 1: Negative			
	F1-31	Encoder installation angle	0.0°		
		0.0° to 359.9°			
		F1-37	Auto-tuning selection	0	

Operation	Para. No.	Parameter Name	Default	Commission
		0: No operation 1: Asynchronous motor static auto-tuning 2: Asynchronous motor no-load complete auto-tuning 3: Asynchronous motor static complete auto-tuning 4: Asynchronous motor inertia auto-tuning (only FVC) 11: Synchronous motor no-load partial auto-tuning (back EMF exclusive) 12: Synchronous motor dynamic no-load auto-tuning 13: Synchronous motor static complete auto-tuning 14: Synchronous motor inertia auto-tuning (only FVC) NOTE: If this parameter is set to 1, 3, 11 or 13, the motor won't rotate at this stage. If this parameter is set to 2, 4, 12 or 14, the motor will rotate. It is better to disconnect the load from the motor shaft for safety. The auto-tuning procedure is as follows: 1) Ensure the drive unit and the motor is not disconnected by an output contactor; if it is, then manually handle with the output contactor; 2) Set F0-02 (Command source selection) to 0 (External LCD panel/Commissioning software) to use the LED operating panel to start the tuning procedure. 3) Set F1-37 (Auto-tuning selection) and press  . The operating panel will display letters "TUNE". 4) Hold down  to enable the motor to start auto-tuning (auto-tuning is canceled if you press ). It usually takes about 30 seconds to finish the auto-tuning. Wait until the LED stops displaying "TUNE".		
Select a command source	F0-02	Command source selection	0	
		0: External LCD panel/Commissioning software 1: Terminal I/O control 2: Communication control		
Select a control mode	F0-01	1st motor control mode	0	
		0: SVC control 1: FVC control 2: V/F control(not supporting synchronous motor)		
Select a frequency reference setting channel	F0-03	Main frequency reference setting channel selection	0	

Operation	Para. No.	Parameter Name	Default	Commission
		0: Digital setting (initial value F0-08 can be modified by the operating panel or terminal UP/Down, non-retentive at power failure) 1: Digital setting (initial value F0-08 can be modified by the operating panel or terminal UP/Down, retentive at power failure) 2: AI1 3: AI2 4: Reserved 5: Pulse setting (DIO1) 6: Multi-reference setting 7: Simple PLC 8: PID 9: Communication setting 10: Synchronization control		
If F0-08 is frequency reference				
Set F0-08	F0-08	Preset frequency	50.00 Hz	
		0.00 Hz to F0-10 (Maximum frequency)		
If AI1 is frequency reference				
Set AI1	F4-13	AI curve 1 minimum input	-10.00 V	
		0 V to F4-15 (AI1 maximum input)		
	F4-14	Corresponding percentage of AI1 minimum input	-100.0%	
		-100.0% to 100.0%		
	F4-15	AI1 maximum input	10.00 V	
		F4-13 (AI curve 1 minimum input) to 10.00 V		
	F4-16	Corresponding percentage of AI1 maximum input	100.0%	
		-100.0% to 100.0%		
If AI2 is frequency reference				
Set AI2	F4-18	AI curve 2 minimum input	0.00 V	
		0.00 V to F4-20 (AI2 maximum input)		
	F4-19	Corresponding percentage of AI2 minimum input	0.0%	
		-100.0% to 100.0%		
	F4-20	AI2 maximum input	10.00 V	

5 Quick Commissioning

Operation	Para. No.	Parameter Name	Default	Commission
If multi-reference is frequency reference		F4-18 (AI curve 2 minimum input) to 10.00 V		
	F4-21	Corresponding percentage of AI2 maximum input	100.0%	
		-100.0% to 100.0%		
Set multi-reference	FC-00	Reference 0	0.0%	
		-100% to 100.0%		
If any digital input is used	FC-01 to FC-15	Reference 1-15	0.0%	
		-100% to 100.0%		
Set DI function	F4-00	DI1 function selection	1	

Operation	Para. No.	Parameter Name	Default	Commission
		0: No function 1: Forward RUN (FWD) 2: Reverse run (REV) 3: Three-wire control 4: Forward jog (FJOG) 5: Reverse jog (RJOG) 6: Terminal UP 7: Terminal DOWN 8: Coast to stop 9: Fault reset (RESET) 10: RUN disabled 11: External fault normally open (NO) input 12: Multi-reference terminal 1 13: Multi-reference terminal 2 14: Multi-reference terminal 3 15: Multi-reference terminal 4 16: Terminal 1 for acceleration/deceleration time selection 17: Terminal 2 for acceleration/deceleration time selection 18: Frequency source switchover 19: UP and DOWN setting clear (terminal, operating panel) 20: Command source switchover 21: Acceleration/Deceleration inhibited 22: PID pause 23: PLC status reset 24: Wobble disabled 25: Counter input (DIO1) 26: Counter reset 27: Length count input (DIO1)		

Operation	Para. No.	Parameter Name	Default	Commission	
		28: Length reset 29: Torque control inhibited 31: Reserved 32: Immediate DC injection braking 33: External fault normally closed (NC) input 34: Frequency modification enabled 35: PID operation direction reverse 36: External stop terminal 1 37: Command source switchover terminal 2 38: PID integral disabled 39: Switchover between main frequency reference and preset frequency reference 40: Switchover between auxiliary frequency reference and preset frequency 41: Reserved 42: Position lock enabled 43: PID parameter switchover 44: User-defined fault 1 45: User-defined fault 2 46: Speed control/Torque control switchover 47: Emergency stop 48: External stop terminal 2 49: Deceleration DC injection braking 50: Clear the current running time 51: Two-wire control/ Three-wire control switchover 52-53: Reserved 54: Winding diameter 55 to 56: Initial winding diameter 57: Pre-drive 58: Winding/Unwinding switchover 59: Winding diameter calculation disabled 60: Exiting tension mode 61: Speed limit direction			
	F4-01	DI2 function selection	4		
		Setting range same as DI1			
	F4-03	DIO1 function selection	12		
		Setting range same as DI1			
	F4-04	DIO2 function selection	13		
		Setting range same as DI1			
If any digital output is used	Set DO function	F5-00	DIO2 output mode selection	0	
		0: Pulse output (FMP) 1: Digital output (FMR)			
	F5-01	FMR function selection	0		



Operation	Para. No.	Parameter Name	Default	Commission
		0: No function 1: AC drive running 2: Fault output 1 (immediate output in coast to stop mode, output after stop in decelerate to stop mode) 3: Frequency-level detection 1 output 4: Frequency reached 5: Zero-speed running (no output at stop) 6: Motor overload pending 7: AC drive overload pending 8: Set count value reached 9: Designated count value reached 10: Length reached 11: PLC cycle completed 12: Accumulative running time reached 13: Frequency limited 14: Torque limited 15: Ready for RUN 16: AI1 > AI2 17: Frequency upper limit reached 18: Frequency lower limit reached (no output at stop) 19: Undervoltage state output 20: Communication setting 23: Zero-speed running 2 (having output at stop) 24: Accumulative power-on time reached 25: Frequency-level detection 2 output 26: Frequency 1 reached 27: Frequency 2 reached 28: Current 1 reached 29: Current 2 reached 30: Timing reached 31: AI1 input limit exceeded 32: Load loss 33: Reverse running 34: Zero current state 35: IGBT temperature reached 36: Output current limit exceeded 37: Frequency lower limit reached (having output at stop) 38: Abnormality output (direct output at fault or warning) 39: Motor overheat pre-warning 40: Current running time reached 41: Fault output 2 (output at coast to stop/decelerate to stop, no output at undervoltage) 43: Position lock enabled (deviation pulses < F6-25)		
	F5-02	Relay function selection	2	
		Setting range same as FMR		
	F5-04	DIO1 function selection	0	

5 Quick Commissioning

Operation	Para. No.	Parameter Name	Default	Commission
If an analog output is used		Setting range same as FMR		
	F5-06	FMP function selection	0	
Set AO function		Setting range same as FMR		
	F5-07	AO function selection	0	
		0: Running frequency 1: Set frequency 2: Output current 3: Output torque (100.0% corresponds to 2 times of rated motor torque) 4: Output power 5: Output voltage (100.0% corresponds to 1.2 times of rated motor voltage) 6: Pulse input (100.0% corresponds to 50.0 kHz) 7: AI1 8: AI2 9: Reserved 10: Length 11: Count value 12: Communication setting 13: Motor speed 14: Output current (100.0% corresponds to 1000.0 A) 15: Output voltage (100.0% corresponds to 1000.0 V) 16: Output torque (directional, 100.0% corresponds to 2 times of rated motor torque)		
Set accel/decel time	F0-17	Acceleration time 1	20.0s	
		0.00s to 65000s		
If smooth acceleration/ deceleration is requested	F0-18	Deceleration time 1	20.0s	
		0.00s to 65000s		
Set S-curve	F6-07	Acceleration/Deceleration mode	0	
		0: Linear acceleration/deceleration 1: S-curve acceleration/deceleration		
	F6-08	Time proportion of S-curve start segment	30.0%	
		0.0% to (100.0% - F6-09)		
	F6-09	Time proportion of S-curve end segment	30.0%	
		0.0% to (100.0% - F6-08)		
If it is V/F control				

Operation	Para. No.	Parameter Name	Default	Commission
Set V/F parameters	F3-00	V/F curve selection	0	
		0: Linear V/F 1: Multi-point V/F 2: Square V/F 3: 1.2-power V/F 4: 1.4-power V/F 6: 1.6-power V/F 8: 1.8-power V/F 9: Reserved 10: V/F complete separation 11: V/F half separation		
	F3-01	Torque boost	0.0%	
		0.0%: Fixed torque boost 0.1% to 30.0%		
	F3-02	Frequency limit of torque boost	50.00 Hz	
		0.00 Hz to F0-10 (Maximum frequency)		
	F3-03	Multi-point V/F frequency 1	0.00 Hz	
		0.00 Hz to F3-05 (Multi-point V/F frequency 2)		
	F3-04	Multi-point V/F voltage 1	0.0	
		0.0 to 100.0 V		
	F3-05	Multi-point V/F frequency 2	0.00 Hz	
		F3-03 (Multi-point V/F frequency 1) to F3-07 (Multi-point V/F frequency 3)		
	F3-06	Multi-point V/F voltage 2	0.0 V	
	0.0 to 100.0 V			
F3-07	Multi-point V/F frequency 3	0.00 Hz		
	F3-05 (Multi-point V/F frequency 2) to F1-04 (Rated motor frequency)			
F3-08	Multi-point V/F voltage 3	0.0 V		
	0.0 to 100.0 V			

5 Quick Commissioning


Operation	Para. No.	Parameter Name	Default	Commission
Trial RUN		Start the drive unit through operating panel control, terminal I/O control, or communication setting. Perform the following trial run steps on the LED operating panel: 1) Set F0-02 (Command source selection) to 0 (External LCD panel/Commissioning software). 2) Go to F8-56 (Jog by LED panel) to set the jog frequency. "JOG" will be displayed. 3) Hold down  or  to forward or reverse. Check if the running performance satisfies your application. If yes, then go forward to the next step; if no, then go back to check.		
If it is SVC or FVC control				
Adjust speed loop parameters	F2-00	Speed loop proportional gain 1	Asynchronous motor: 30 Synchronous motor: 20	
To achieve better performance		0 to 100		
	F2-01	Speed loop integral time 1	0.500s	
		0.001s to 10.000s		
	F2-02	Switchover frequency 1	5.00 Hz	
		0.00 Hz to F2-05 (Switchover frequency 2)		
	F2-03	Speed loop proportional gain 2	20	
		1 to 200		
	F2-04	Speed loop integral time 2	1.000s	
	0.001s to 10.000s			
F2-05	Switchover frequency 2	10.00 Hz		
	F2-02 (Switchover frequency 1) to F0-10 (Maximum frequency)			
Finish				


6 Troubleshooting

This chapter describes only the troubleshooting of the drive unit. For the troubleshooting of the power supply unit, see "810 Series Power Supply Unit User Guide".


6.1 Fault Display and Solutions



The drive is designed with the fault level and alarm level for problem locating purposes. Fault takes precedence over alarm during troubleshooting.

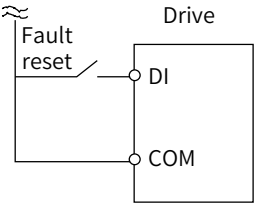
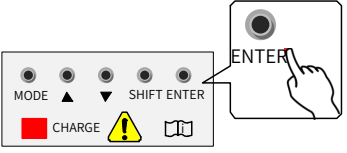
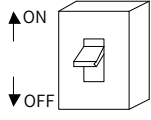
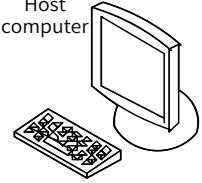
1) Example of fault display: 

2) Example of alarm display: 

When a fault occurs during running, the drive stops output immediately, the fault

indicator  flashes in red, and the contact of the fault relay acts. The following table lists the fault types and solutions for specific fault codes. The following information is for your reference only. Do not repair or modify the drive by yourself. If the fault cannot be eliminated, contact the agent or Inovance.

Stage	Solution	Remarks
After the fault occurs	Check the operating panel for detailed information of recent three faults, such as fault type and frequency, current, bus voltage, DI/DO state, accumulative power-on time, accumulative running time, IGBT temperature, and fault subcode at the occurrence of the faults.	View the information using F9-14 (1st fault type) to F9-46 (1st fault subcode).  ... 
Before the fault is reset	Find and remove the fault cause. Then follow the steps below to reset the fault.	Troubleshoot the fault according to "6.2 Fault Codes and Solutions" .

Stage	Solution	Remarks
Fault resetting method	1) Allocate a DI terminal with function 9 "Fault reset (RESET)" by setting any of F4-00 (DI1 function selection) to F4-04 (DIO2 function selection) to 9 (Fault reset).	
	2) Press the ENTER key on the operating panel.	
	3) Automatic resetting Disconnect the main circuit power supply. Wait until the fault code disappears, and connect the power supply again.	
	4) Fault resetting using the host controller Confirm that F0-02 (Command source selection) is set to 2 (Communication control) and write "7" (fault reset) to communication address 2000H. [1]	

6.2 Fault Codes and Solutions

Fault Name	Operating Panel Display	Cause	Possible Solution
Abnormal current sampling	E 01.01	The current sampling circuit is faulty.	Check whether mains power supply is on. Contact the agent or Inovance.
Product model setup error	E 01.05	Product model and hardware do not match.	Check whether the equipment model is wrong.
STO product model setup error	E 01.06	Product hardware does not support STO.	Check whether there is no STO product model, and contact the manufacturer if so.

Fault Name	Operating Panel Display	Cause	Possible Solution
Overcurrent during acceleration	E 02.00	Ground fault or short circuit exists in the output circuit.	Check whether short-circuit occurs on the motor, motor cable, or contactor.
		The control mode is SVC or FVC but motor auto-tuning is not performed.	Set motor parameters according to motor nameplate and perform motor auto-tuning.
		Acceleration time is too short.	Increase acceleration time.
		The overcurrent stall prevention parameters are set improperly.	Ensure that current limit is enabled (F3-19 = 1). The setting of F3-18 (Current limit level) is too large. Adjust it between 120% and 160%. The setting of F3-20 (Current limit gain) is too small. Adjust it between 20 and 40.
		Customized torque boost or V/F curve is not appropriate.	Adjust the customized torque boost or V/F curve.
		The spinning motor is started.	Enable the catching a spinning motor function or start the motor after it stops.
		The drive suffers external interference.	View historical fault records. If the current value is far from the overcurrent level, find the interference source. If an external interference does not exist, the drive board or hall device may be faulty.

Fault Name	Operating Panel Display	Cause	Possible Solution
Overcurrent during deceleration	E 03.00	Ground fault or short circuit exists in the output circuit.	Check whether short-circuit occurs on the motor, motor cable, or contactor.
		The control mode is SVC or FVC but motor auto-tuning is not performed.	Set the motor parameters according to the motor nameplate and perform motor auto-tuning.
		Deceleration time is too short.	Increase deceleration time.
		The overcurrent stall prevention parameters are set improperly.	Ensure that current limit is enabled (F3-19 = 1). The setting of F3-18 (Current limit level) is too large. Adjust it between 120% and 150%. The setting of F3-20 (Current limit gain) is too small. Adjust it between 20 and 40.
		The braking unit and braking resistor are not installed.	Install the braking unit and braking resistor.
		The drive suffers external interference.	View historical fault records. If the current value is far from the overcurrent level, find the interference source. If an external interference does not exist, the drive board or hall device is faulty.

Fault Name	Operating Panel Display	Cause	Possible Solution
Overcurrent at constant speed	E 04.00	Ground fault or short circuit exists in the output circuit.	Check whether short-circuit occurs on the motor, motor cable, or contactor.
		The control mode is SVC or FVC but motor auto-tuning is not performed.	Set motor parameters according to motor nameplate and perform motor auto-tuning.
		The overcurrent stall prevention parameters are set improperly.	Ensure that current limit is enabled (F3-19 = 1). The setting of F3-18 (Current limit level) is too large. Adjust it between 120% and 150%. The setting of F3-20 (Current limit gain) is too small. Adjust it between 20 and 40.
		The drive power class is small.	If the output current exceeds the rated motor current or rated output current of the drive during stable running, replace a drive of larger power class.
		The drive suffers external interference.	View historical fault records. If the current value is far from the overcurrent level, find the interference source. If an external interference does not exist, the drive board or hall device is faulty.
Overvoltage during acceleration	E 05.00	Input voltage is too high.	Adjust the input voltage to normal range.
		An external force drives the motor during acceleration.	Cancel the external force or install a braking resistor. The setting of F3-26 (Frequency rise threshold during voltage limit) is too small. Adjust it between 5 Hz and 15 Hz.
		The overvoltage stall prevention parameters are set improperly.	Ensure that the voltage limit function is enabled (F3-23 = 1). The setting of F3-22 (Voltage limit) is too large. Adjust it between 700 V and 770 V. The setting of F3-24 (Frequency gain for voltage limit) is too small. Adjust it between 30 and 50.
		The braking unit and braking resistor are not installed.	Install the braking unit and braking resistor.
		Acceleration time is too short.	Increase acceleration time.

Fault Name	Operating Panel Display	Cause	Possible Solution
Overvoltage during deceleration	E 06.00	The overvoltage stall prevention parameters are set improperly.	Ensure that the voltage limit function is enabled (F3-23 = 1). The setting of F3-22 (Voltage limit) is too large. Adjust it between 700 V and 770 V. The setting of F3-24 (Frequency gain for voltage limit) is too small. Adjust it between 30 and 50.
		An external force drives the motor during acceleration.	Cancel the external force or install a braking resistor. The setting of F3-26 (Frequency rise threshold during voltage limit) is too small. Adjust it between 5 Hz and 15 Hz.
		Deceleration time is too short.	Increase deceleration time.
		The braking unit and braking resistor are not installed.	Install the braking unit and braking resistor.
Overvoltage at constant speed	E 07.00	The overvoltage stall prevention parameters are set improperly.	Ensure that the voltage limit function is enabled (F3-23 = 1). The setting of F3-22 (Voltage limit) is too large. Adjust it between 700 V and 770 V. The setting of F3-24 (Frequency gain for voltage limit) is too small. Adjust it between 30 and 50.
		An external force drives the motor during acceleration.	Cancel the external force or install a braking resistor. The setting of F3-26 (Frequency rise threshold during voltage limit) is too small. Adjust it between 5 Hz and 15 Hz.
Undervoltage	E 09.00	Instantaneous power failure occurs.	Enable the power dip ride through function (F9-59 ≠ 0).
		The drive's input voltage is not within the permissible range.	Adjust the voltage to the normal range.
		The bus voltage is abnormal.	Contact the agent or Inovance.
		The rectifier bridge, the drive board, or the control board are abnormal.	Contact the agent or Inovance.

Fault Name	Operating Panel Display	Cause	Possible Solution
Drive overload	E 10.00	The load is too heavy or locked-rotor occurs on the motor.	Reduce the load or check motor and mechanical conditions.
		The drive power class is small.	Replace a drive of larger power class.
		The control mode is SVC or FVC but motor auto-tuning is not performed.	Set motor parameters according to motor nameplate and perform motor auto-tuning.
		The control mode is V/F but the setting of F3-01 (Torque boost) is too large.	Decrease the setting of F3-01 (Torque boost) by 1.0% gradually or set F3-01 to 0 (Auto torque boost).
		Output phase loss occurs on the drive.	Check the output wiring of the drive.
Pulse-by-pulse current limit fault	E 40.01	The load is too heavy or locked-rotor occurs on the motor.	Reduce the load or check motor and mechanical conditions. Replace a drive of larger power class.
		The drive power class is small.	
Motor overload	E 11.00	F9-01 (Motor overload protection gain) is set improperly.	Set F9-01 correctly. Increase its value to prolong the motor overload time.
		The load is too heavy or locked-rotor occurs on the motor.	Reduce the load or check motor and mechanical conditions.
Abnormal input voltage	E 12.01	Input phase loss	Check and ensure:
	E 12.02		The power supply is normal.
	E 12.03	The input power cables are intact.	
	E 12.04	The input power cables are properly connected.	
	E 12.05	Voltage detection circuitry is normal.	
	E 12.04	Input voltage is too high.	Adjust the input voltage within the normal range.
	E 12.05	Three-phase inputs voltage is imbalanced.	Check and ensure: The power supply is normal. Voltage detection circuitry is normal.

Fault Name	Operating Panel Display	Cause	Possible Solution
Output phase loss	E 13.00	The motor is faulty.	Check and ensure: The motor is without open circuit.
		The cable connecting the drive and the motor is abnormal.	Eliminate external faults.
		The drive's three-phase outputs are unbalanced when the motor is running.	Check whether the motor three-phase winding is normal.
		The drive board or the IGBT is abnormal.	Contact the agent or Inovance.
IGBT overheat	E 14.00	The ambient temperature is too high.	Lower the ambient temperature.
		The ventilation is clogged.	Clean the ventilation.
		The fan is damaged.	Replace the cooling fan.
		The thermistor of IGBT is damaged.	Contact the agent or Inovance.
		The IGBT is damaged.	
External fault	E 15.01	An external fault signal is input using DI (NO).	Eliminate external faults. And confirm that the mechanical condition allows restart (F8-18) and reset the operation.
	E 15.02	An external fault signal is input using DI (NC).	

Fault Name	Operating Panel Display	Cause	Possible Solution
Communication fault	E 16.01	Modbus communication times out.	Check whether the RS485 communication cable is correctly connected. Check whether Fd-04 (Modbus communication timeout) and PLC communication cycle are properly set.
	E 16.11	CANopen communication times out.	Check whether CAN communication cable is correctly connected. Check parameters Fd-15 (Maximum value of node receiving error counter) to Fd-17 (CANopen/CANlink bus disconnection times in a period) for further action.
	E 16.12	PDO mapping configured by CANopen does not match the actual communication mapping	Check the PDO mapping in group AF.
	E 16.13	Timeout occurs on transmitting interactive data from the power supply unit to the drive unit.	Check whether the power supply unit is in operation. Check whether the communication cable from the power supply unit to the drive unit is correctly connected. Check whether the termination resistor is properly connected. Check whether Fd-12 (CAN baud rate) is correctly set.
	E 16.14	The interactive data from the power supply unit to the drive unit is abnormal.	The power supply unit is faulty. Eliminate the faults.
	E 16.15	Synchronous control communication times out.	Check the group A8 parameters to see whether the master station number is correct, and check whether the CAN2 cable is connected normally.
	E 16.21	CANlink heartbeat times out.	Check whether CAN communication cable is correctly connected. Check parameters Fd-15 (Maximum value of node receiving error counter) to Fd-17 (CANopen/CANlink bus disconnection times in a period) for further action.

Fault Name	Operating Panel Display	Cause	Possible Solution
Communication fault	E 16.22	Conflicts are caused by the same CANlink station number.	Modify the CAN station numbers by using Fd-13 (CAN station No.).
	E 16.31	DP communication times out (DP to CANopen bridge protocol).	Check whether DP communication cable is correctly connected.
Communication fault	E 16.34	Slaves are offline (DP to CANopen bridge).	Check whether the number displayed in “The number of devices” of PLC matches the actual quantity of stations. Check whether the station numbers of slaves are correctly set.
	E 16.35	DP to CANopen bridge configuration parameters are set incorrectly.	Check whether the value of “NO. n” of PLC is consistent with that of AF-66/67 (Number of valid RPDOs/Number of valid TPDOs).
	E 16.41	DP communication times out.	Check whether the DP communication cable is correctly connected.
	E 16.42	DP to CANopen bridge configuration parameters are set incorrectly.	Check whether the value of “NO. 1” of PLC is consistent with that of AF-66/67 (Number of valid RPDOs/Number of valid TPDOs).
External DC soft charge unit error	E 17.05	The external DC soft charge unit is not connected or fails.	Check whether an external DC soft charge unit is needed. If not, restore the tens digit of F9-49 (Fault protection action selection 2) to the default value 5 (Cancelled).

Fault Name	Operating Panel Display	Cause	Possible Solution
Motor auto-tuning fault	E 19.02	Synchronous motor magnetic pole angle auto-tuning is faulty.	The motor is not connected or output phase loss occurs.
	E 19.04		
	E 19.05	Synchronous motor initial magnetic pole angle auto-tuning is faulty.	Increase the setting of F2-29 (Synchronous motor initial angle detection current).
	E 19.06	Stator resistance auto-tuning is faulty.	The motor is not connected. Set F1-03 (Rated motor current) according to the motor nameplate.
	E 19.07		
	E 19.08		
	E 19.09	Asynchronous motor instantaneous leakage inductive reactance auto-tuning is faulty.	The motor is not connected or output phase loss occurs.
	E 19.10		
	E 19.11	Inertia auto-tuning is faulty.	Set F1-03 (Rated motor current) according to the motor nameplate. Increase the setting of F2-43 (Inertia auto-tuning and dynamic speed reference).
	E 19.12	Timeout occurs on auto-tuning.	The motor is not connected or output phase loss occurs. Confirm the load is disconnected from the motor.
	E 19.13		
E 19.14			
E 19.15			
E 19.16			
E 19.17			
E 19.19			
Motor auto-tuning fault	E 19.20	Timeout occurs on synchronous motor no-load zero position angle auto-tuning.	Check feedback signal Z.
	E 19.22		
	E 19.23	Synchronous motor magnetic pole angle auto-tuning is faulty.	Set F1-03 (Rated motor current) according to the motor nameplate. Decrease the setting of F2-29 (Synchronous motor initial angle detection current).
	E 19.24	Asynchronous motor instantaneous leakage inductive reactance auto-tuning is faulty.	The drive power class is small. Select the proper drive according to the power of motor.

Fault Name	Operating Panel Display	Cause	Possible Solution
Encoder fault	E 20.00	Encoder wire-break occurs.	Repair the wire-break. Confirm the wiring of PG card is correct. Confirm the actual encoder pulses per revolution matches the setting value of F1-27 (Encoder pulses per revolution). Confirm the wiring of signal AB is correct.
	E 20.01	The encoder is faulty.	
	E 20.02	Encoder wire-break occurs.	
	E 20.03	The synchronous motor no-load auto-tuning encoder is faulty.	
	E 20.04	The synchronous motor no-load auto-tuning encoder is faulty.	
	E 20.06	The synchronous motor auto-tuning encoder is faulty.	
	E 20.07	The synchronous motor no-load auto-tuning encoder is faulty.	
	E 20.08	The synchronous motor no-load auto-tuning encoder is faulty.	Check feedback signal Z and the wiring of PG card.
	E 20.09	The synchronous motor with-load auto-tuning encoder is faulty.	
	E 20.10	The synchronous motor encoder is faulty.	
	E 20.11	The asynchronous motor FVC no-load auto-tuning encoder is faulty.	Confirm the encoder is correctly connected. Confirm the actual encoder pulses per revolution matches the setting value of F1-27 (Encoder pulses per revolution).
	E 20.12	The error between encoder feedback speed and speed estimated by SVC is too large.	Confirm the encoder is correctly connected. Confirm the motor parameters is correctly set. Confirm motor auto-tuning is performed.
	E 20.13	The resolver wire-break occurs.	Confirm the resolver is correctly connected.

Fault Name	Operating Panel Display	Cause	Possible Solution
EEPROM read-write fault	E 21.01	EEPROM read/write is abnormal.	<p>1. If the writing is done through communication, ensure that you use the RAM address of the parameter. For the mapping rules of all RAM addresses to parameters, see Appendix A "Group AF: Process Data Address Mapping".</p> <p>2. The EEROM chip is damaged. Contact the manufacturer to replace the control board.</p>
	E 21.02		
	E 21.03		
	E 21.04		
Motor auto-tuning warning	E 22.00	The asynchronous motor stator resistance after auto-tuning is over range.	<p>Set Group F1 (Motor 1 Parameters) according to the motor nameplate.</p> <p>Perform auto-tuning when the motor is stopped.</p>
	E 22.01	The asynchronous motor rotor resistance after auto-tuning is over range.	
	E 22.02	The asynchronous motor no-load current and mutual inductive reactance are over range. The no-load current and mutual inductive reactance is calculated according to the motor parameters and may be slightly inaccurate.	<p>Set Group F1 (Motor 1 Parameters) according to the motor nameplate.</p> <p>Confirm the motor is disconnected from the load.</p>
	E 22.03	The synchronous motor back EMF after auto-tuning is over range.	<p>Set F1-02 (Rated motor voltage) according to the motor nameplate.</p> <p>Confirm the motor is disconnected from the load.</p>
	E 22.04	Inertia auto-tuning is faulty.	Set F1-03 (Rated motor current) according to the motor nameplate.
Short circuit to ground	E 23.00	The motor is short-circuited to the ground.	Replace the cable or motor.
Phase to phase short circuit	E 24.00	Phase to phase short circuit occurs on the motor.	Check whether short-circuit occurs on the output UVW.

Fault Name	Operating Panel Display	Cause	Possible Solution
Power supply unit fault (to be continued)	E 25.00	The power supply unit is faulty.	<p>Eliminate the fault, such as input phase loss and overheat.</p> <p>Check the terminal configuration. If any of the following functions is selected, a fault is reported when there is no feedback signal:</p> <ol style="list-style-type: none"> 1: Operation enable 2: Incoming breaker feedback 3: Auxiliary breaker feedback 4: Leakage breaker feedback <p>If any of the following functions is selected, a fault is reported when the terminal is active.</p> <ol style="list-style-type: none"> 6: Drive unit operation forbidden 7: Drive unit coast-to-stop 8: Drive unit shutdown by setting
	E 25.12	The grid voltage is abnormal.	<ol style="list-style-type: none"> 1: Check whether the three-phase power supply is normal. 2: Check whether the input cables break. 3: Check whether input terminals are connected properly. 4: Check the hardware voltage detection circuit. 5: Adjust the three-phase voltage to the allowable range. 6: Check whether the three-phase power supply is normal. 7: Check the hardware voltage detection circuit.
	E 25.14	The IGBT is overheating.	<ol style="list-style-type: none"> 1: Lower the ambient temperature. 2: Clean the air duct. 3: Replace the fan. 4: Contact Inovance or the agent for technical support.

Fault Name	Operating Panel Display	Cause	Possible Solution
Power supply unit fault (continued)	E 25.16	A communication fault occurs.	<p>1: Check whether the RS485 communication cable is connected properly.</p> <p>2: Check whether the setting of Fd-04 (Modbus communication timeout) and PLC communication period are reasonable.</p> <p>3: Check whether the CAN communication cable is connected properly.</p> <p>4: Check Fd-15 (Maximum value of node receiving error counter) to Fd-17 (CANopen/CANlink bus disconnection times in a period) to obtain the interference information.</p> <p>5: Check the PDO mapping of parameters in group AF.</p> <p>6: Check whether the power supply unit is working.</p> <p>7: Check whether the network cables are connected for the power supply unit and drive unit.</p> <p>8: Check whether the termination resistor is connected properly.</p> <p>9: Check Fd-12 (CAN baud rate) to see whether the CAN baud rate is consistent.</p> <p>10: If the power supply unit is faulty, rectify the fault.</p> <p>11: Check Fd-15 (Maximum value of node receiving error counter) to Fd-17 (CANopen/CANlink bus disconnection times in a period) to obtain the interference information.</p> <p>12: Check the PDO mapping of parameters in group AF.</p> <p>13: Modify the CAN station numbers by using Fd-13 (CAN station No.).</p> <p>14: Check whether the PROFIBUS-DP cable is connected properly.</p> <p>15: Check whether the number displayed in "The number of devices" of PLC matches the actual quantity of stations.</p> <p>16: Check whether the station numbers of slaves are correctly set.</p> <p>17: Check whether the value of "NO.n" of PLC is consistent with that of AF-66/67 (Number of valid RPDOs/Number of valid TPDOs).</p> <p>18: Check whether the PROFIBUS-DP cable is connected properly.</p> <p>19: Check whether the value of "No.1" of PLC is consistent with that of AF-66/67 (Number of valid RPDOs/Number of valid TPDOs).</p>


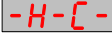

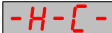

Fault Name	Operating Panel Display	Cause	Possible Solution
Power supply unit fault (continued)	E 25.21	The EEPROM is faulty.	1: Contact Inovance or the agent for technical support.
	E 25.61	The braking unit is faulty.	1: Check whether the braking resistor is short circuited. 2: Check whether the braking pipe shoots through. 3: Check whether the braking resistance and power class of the drive are too small. 4: Check whether external interference exists. 5: Check whether the hardware circuit detection is normal. 6: Check whether the braking resistance and power class of the drive are too small. 7. Lower the ambient temperature. 8: Check whether the cooling fan works properly. 9: Clean the air duct. 10: Check whether the temperature sensor is damaged.
Accumulative running time reached	E 26.00	The accumulative running time reached the set value.	Clear the record by parameter initialization.
User-defined fault 1	E 27.00	The signal of user-defined fault 1 is input through the multi-functional terminal DI.	Perform the reset operation.
		The signal of user-defined fault 1 is input through the multifunctional terminal IO.	Perform the reset operation.
User-defined fault 2	E 28.00	The signal of user-defined fault 2 is input through the multi-functional terminal DI.	Perform the reset operation.
		The signal of user-defined fault 2 is input through the multifunctional terminal IO.	Perform the reset operation.

Fault Name	Operating Panel Display	Cause	Possible Solution
Accumulative power-on time reached	E 29.00	The accumulative power-on time reached the set value.	Clear the record by parameter initialization.
Load becomes 0	E 30.00	The operation current of the drive is smaller than F9-64 (Load loss detection level).	Check whether the load becomes 0 or ensure that F9-64 (Load loss detection level) and F9-65 (Load loss detection time) are set based on the actual conditions.
PID Feedback loss	E 31.00	PID feedback is smaller than FA-26 (Detection level of PID feedback loss)	Check the PID feedback signal or set FA-26 correctly.
Speed error	E 42.00	Encoder parameters are set improperly.	Set encoder parameters properly.
		Motor auto-tuning is not performed.	Perform motor auto-tuning.
		F9-69 (Detection level of speed error) and F9-70 (Detection time of speed error) are set incorrectly.	Set F9-69 and F9-70 correctly based on actual condition.
Motor overspeed	E 43.00	Encoder parameters are set improperly.	Set encoder parameters properly.
		Motor auto-tuning is not performed.	Perform motor auto-tuning.
		F9-67 (Overspeed detection level) and F9-68 (Overspeed detection time) are set incorrectly.	Set F9-67 and F9-68 correctly based on the actual situation.
Motor overheat	E 45.00	Cable connection of the temperature sensor becomes loose.	Check cable connection of the temperature sensor.
		The motor temperature is too high.	Increase carrier frequency or take other measures to cool the motor.
		The setting of F9-57 (Motor overheat protection threshold) is too small.	Adjust the setting of motor overheat protection threshold between 90° C to 100° C.

Fault Name	Operating Panel Display	Cause	Possible Solution
Improper master/slave setting	E 46.01	The setting of A8-10 (Master/Slave selection in speed and position control), A8-50 (Master/Slave selection in load allocation) and A8-70 (Master/Slave selection in droop control) are different.	Set A8-10, A8-50 and A8-70 to Slave.
STO fault	E 47.00	An STO fault occurred.	Check whether F8-54 (STO function) is set to 1 (Enabled). If STO is enabled, check whether drive unit terminals STO1 and STO2 have 24 V input.
Position deviation large	E 55.00	In position synchronization mode, the pulse deviation is too large, the main reason is that the slave can not follow the host pulse, the detection principle is that when the host and slave pulse deviation value is more than A8-32 (Value detection of position error), and the duration is more than A8-33 (Time detection of position error).	Set A8-32 and A8-33.
Braking fault	E 61.01	Shoot-through of braking unit	Ensure that the brake pipe is normal; Check whether there is an external resistor.
	E 61.02	Overcurrent of braking unit	Increase the braking resistance; Troubleshoot the over-high bus voltage.
	E 61.03	Overload of braking unit	
	E 61.04	Overheated brake pipe	Troubleshoot the over-high bus voltage; Decrease the ambient temperature. Ensure that the air duct is not clogged; Ensure that the fan works normally. Ensure that the thermistor works normally. Ensure that the brake pipe is normal.

Fault Name	Operating Panel Display	Cause	Possible Solution
Fan fault	E 80.00	Fan fault	Ensure that the fan on the drive unit is connected correctly. Ensure that the fan rotates freely.

6.3 Common Symptoms and Solutions

No.	Fault Symptom	Possible Cause	Solution
1	There is no display upon power-on. 	There is no power supply to the drive or the power input to the drive is too low.	Check the power supply.
		The switch-mode power supply on the drive board of the drive is faulty.	Check the bus voltage.
		The control board or the operating panel is faulty.	Contact the agent or Inovance for technical support.
		The rectifier bridge is damaged.	
2	"HC" is displayed upon power-on. 	Related components on the control board are damaged.	Contact the agent or Inovance for technical support.
		The motor or the motor cable is short-circuited to the ground.	
		The hall device is faulty.	
		The mains voltage is too low.	
3	"E23.00" is displayed upon power-on. 	The motor or the motor cable is short-circuited to the ground.	Check the insulation status of the motor and the output cable with a megger.
		The drive is damaged.	Contact the agent or Inovance for technical support.
4	The drive display is normal upon power-on, but after running the drive displays "HC" and stops immediately. 	The cooling fan is damaged or does not rotate.	Replace the damaged fan.
		The cable of the external control terminal is short-circuited.	Eliminate the external short-circuit fault.
5	Err14 (IGBT overheat) is detected frequently. 	The carrier frequency is set too high.	Reduce F0-15 (Carrier frequency).
		The cooling fan is damaged, or the air filter is blocked.	Replace the cooling fan and clean the air filter.
		Components (thermal coupler or others) inside the drive are damaged.	Contact the agent or Inovance for technical support.

No.	Fault Symptom	Possible Cause	Solution
6	The motor does not rotate after the drive runs.	Check the motor and the motor cables.	Check that cabling between the AC drive and the motor is normal.
		The motor parameters in group F1 are set improperly.	Restore the factory parameters and re-set the following parameters properly: Encoder parameters Motor ratings, such as rated motor frequency and rated motor speed F0-01 (1st motor control mode) and F0-02 (Command source selection) F3-01 (Torque boost) in V/F control under heavy-load start
		The drive board is faulty.	Contact the agent or Inovance for technical support.
7	DI terminals are disabled.	The related parameters are set incorrectly.	Check and reset the parameters in group F4 again.
		The external signal is incorrect.	Re-connect the external signal cable.
		The jumper across OP and +24 V becomes loose.	Re-confirm the jumper bar across OP and +24 V.
		The control board is faulty.	Contact the agent or Inovance for technical support.
8	Motor speed does not rise in FVC control.	The encoder is faulty.	Replace encoder and re-confirm cable connection.
		The PG card is faulty.	Contact the agent or Inovance for technical support.
		The drive board is faulty.	
9	The drive detects overcurrent and overvoltage frequently.	The motor parameters in group F1 are set improperly.	Set the motor parameters in group F1 or perform motor auto-tuning again.
		The acceleration/deceleration time is improper.	Set proper acceleration/ deceleration time.
		The load fluctuates.	Contact the agent or Inovance for technical support.
10	The drive coasts to stop or has no DC injection braking during deceleration or deceleration to stop	Encoder suffers wire-break or voltage limit function is enabled (F3-23 = 1).	If the drive is in FVC control (F0-01 = 1), re-confirm encode cable connection. If the braking resistor is installed, disable voltage limit function (F3-23 = 0).

No.	Fault Symptom	Possible Cause	Solution
11	Deceleration or motor coast to stop at deceleration or no braking ability	Encoder cable is broke or speed lost protection is valid.	Check the encoder wiring at FVC (F0-01 = 1): If the braking resistor has been configured, set the voltage limit selection parameter to invalid (F3-23 = 0).

Note for dual-axis models:

- When A1 is selected to be the current axis, and failed somehow, the operating screen shows a corresponding fault code directly.
- If the A2 fails and A1 does not, the screen displays **A2-Err** to show A2 axis failure.
- If the current axis is A2, and A1 axis fails, the screen displays the **A1-Err** failure notice.
- If both axes are faulty, then the screen shows current axis failure notice directly.

Fault name	Screen Display	Fault Cause	Fault Handling
A1 axis fault indication	A1-Err	A1 axis fails due to the corresponding A1 fault code	Handle the fault based on the fault code.
A2 axis fault indication	A2-Err	A2 axis fails due to the corresponding A2 fault code	Handle the fault based on the fault code.

Appendix A Parameter Table

This chapter describes only the parameters of the drive unit. For the parameters of the power supply unit, see "810 Series Power Supply Unit User Guide".

The drive provides a security protection function that requires a user-defined password. Function parameter FP-00 (User Password) controls this function. Set a non-zero value for FP-00 to enable password protection. To disable password protection, set the value of FP-00 at zero.

The password protection only applies to the operation using the operating panel. Enter the password to view and modify the function parameters. Viewing or modifying the function parameters (groups FP and FF exclusive) through communication is not protected by the password.

The user-defined function parameters are not protected by the password.

Groups F and A include standard function parameters. Group U includes the monitoring function parameters.

The parameter description tables in this chapter use the following symbols.

The symbols in the parameter table are described as follows:

Symbol	Meaning
☆	It is possible to modify the parameter with the drive in the Stop and in the Run status.
★	It is not possible to modify the parameter with the drive in the Run status.
●	The parameter is the actual measured value and cannot be modified.
*	The parameter is a factory parameter and can be set only by the manufacturer.

A.1 Basic Parameters

Para. No.	Para. Name	Setting Range	Default	Property
Group F0: Basic Function Parameters				
F0-00	G/P type display	1: G type (constant-torque load)	Model dependent	●
F0-01	1st motor control mode	0: Sensorless vector control (SVC) 1: Feedback vector control (FVC) 2: Voltage/Frequency control (V/F control, not supporting synchronous motor)	0	★
F0-02	Command source selection	0: External LCD panel/Commissioning software 1: Terminal I/O control 2: Communication control	0	★

Para. No.	Para. Name	Setting Range	Default	Property
F0-03	Main frequency reference setting channel selection	0: Digital setting (initial value F0-08 can be modified by operating panel or terminal UP/Down, non-retentive at power failure) 1: Digital setting (initial value F0-08 can be modified by operating panel or terminal UP/Down, retentive at power failure) 2: AI1 3: AI2 4: Reserved 5: Pulse reference (DIO1) 6: Multi-reference 7: Simple PLC 8: PID reference 9: Communication setting 10: Synchronization control	0	★
F0-04	Auxiliary frequency reference setting channel selection	Same as F0-03	0	★
F0-05	Base value of range of auxiliary frequency reference for main and auxiliary calculation	0: Maximum frequency (F0-10) 1: Main frequency reference	0	☆
F0-06	Range of auxiliary frequency reference for main and auxiliary calculation	0% to 150%	100%	☆

Appendix A Parameter Table

Para. No.	Para. Name	Setting Range	Default	Property
F0-07	Final frequency reference setting selection	Ones: Final frequency reference selection 0: Main frequency reference 1: Main and auxiliary calculation result (determined by the tens position) 2: Switchover between main frequency reference and auxiliary frequency reference 3: Switchover between main frequency reference and main and auxiliary calculation result 4: Switchover between auxiliary frequency reference and main and auxiliary calculation result Tens: Main and auxiliary calculation relationship 0: Main + Auxiliary 1: Main - Auxiliary 2: Max. (main, auxiliary) 3: Min. (main, auxiliary) 4: Main x Auxiliary	0	☆
F0-08	Preset frequency	0.00 Hz to maximum frequency (F0-10)	50.00 Hz	☆
F0-09	Running direction	0: Run in the default direction 1: Run in the direction reverse to the default direction	0	☆
F0-10	Maximum frequency	50.00 to 600.00 Hz	50.00 Hz	★
F0-11	Setting channel of frequency reference upper limit	0: Set by F0-12 1: AI1 2: AI2 4: Pulse reference (DIO1) 5: Communication setting 6: Multi-reference	0	★
F0-12	Frequency reference upper limit	Frequency reference lower limit (F0-14) to maximum frequency (F0-10)	50.00 Hz	☆
F0-13	Frequency reference upper limit offset	0.00 Hz to maximum frequency (F0-10)	0.00 Hz	☆
F0-14	Frequency reference lower limit	0.00 Hz to frequency reference upper limit (F0-12)	0.00 Hz	☆
F0-15	Carrier frequency	0.8–12.0 kHz	Model dependent	☆
F0-16	Carrier frequency adjusted with temperature	0: No 1: Yes	1	☆

Para. No.	Para. Name	Setting Range	Default	Property
F0-17	Acceleration time 1	0.00s to 65000s	20.0s	☆
F0-18	Deceleration time 1	0.00s to 65000s	20.0s	☆
F0-19	Acceleration/ Deceleration time unit	0: 1s 1: 0.1s 2: 0.01s		★
F0-21	Frequency offset of auxiliary frequency setting channel for main and auxiliary calculation	0.00 Hz to maximum frequency (F0-10)	0.00 Hz	☆
F0-22	Frequency reference resolution	1: 0.1 Hz 2: 0.01 Hz	2	★
F0-23	Retentive of digital setting frequency upon stop	0: Not retentive 1: Retentive	0	☆
F0-25	Acceleration/ Deceleration time base frequency	0: Maximum frequency (F0-10) 1: Frequency reference 2: 100 Hz	0	★
F0-26	Base frequency for UP/ DOWN modification during running	0: Running frequency 1: Frequency reference	0	★
F0-27	Main frequency reference coefficient	0.00% to 100.00%	10.00%	☆
F0-28	Auxiliary frequency coefficient	0.00% to 100.00%	10.00%	☆
Group F1: 1st Motor Parameters				
F1-00	Motor type selection	0: Common asynchronous motor 1: Variable frequency asynchronous motor 2: Synchronous motor	0	★
F1-01	Rated motor power	0.1 to 1000.0 kW	Model dependent	★
F1-02	Rated motor voltage	1 to 2000 V	Model dependent	★
F1-03	Rated motor current	0.01 to 655.35 A (drive unit power ≤ 55 kW) 0.1 to 6553.5 A (drive unit power > 55 kW)	Model dependent	★
F1-04	Rated motor frequency	0.01 Hz to maximum frequency (F0-10)	Model dependent	★
F1-05	Rated motor speed	1 to 65535 RPM	Model dependent	★

Appendix A Parameter Table

Para. No.	Para. Name	Setting Range	Default	Property
F1-06	Asynchronous/ Synchronous motor stator resistance	0.001 to 65.535 Ω (drive unit power \leq 55 kW) 0.0001 to 6.5535 Ω (drive unit power > 55 kW)	Auto-tuned	★
F1-07	Asynchronous motor rotor resistance	0.001 to 65.535 Ω (drive unit power \leq 55 kW) 0.0001 Ω to 6.5535 Ω (drive unit power > 55 kW)	Auto-tuned	★
F1-08	Asynchronous motor leakage inductive reactance	0.01 to 655.35 mH (drive unit power \leq 55 kW) 0.001 to 65.535 mH (drive unit power > 55 kW)	Auto-tuned	★
F1-09	Asynchronous motor mutual inductive reactance	0.1 to 6553.5mH (drive unit power \leq 55 kW) 0.01 to 655.35 mH (drive unit power > 55 kW)	Auto-tuned	★
F1-10	Asynchronous motor no-load current	0.01 A to F1-03 (drive unit power \leq 55 kW) 0.1 A to F1-03 (drive unit power > 55 kW)	Auto-tuned	★
F1-11	Asynchronous motor iron-core saturation coefficient 1	50.0% to 100.0%	86.0%	☆
F1-12	Asynchronous motor iron-core saturation coefficient 2	100.0% to 150.0%	130.0%	☆
F1-13	Asynchronous motor iron-core saturation coefficient 3	100.0% to 170.0%	140.0%	☆
F1-14	Asynchronous motor iron-core saturation coefficient 4	100.0% to 180.0%	150.0%	☆
F1-17	Synchronous motor axis D inductance	0.01 to 655.35 mH (drive unit power \leq 55 kW) 0.001 to 65.535 mH (drive unit power > 55 kW)	Auto-tuned	★
F1-18	Synchronous motor axis Q inductance	0.01 to 655.35 mH (drive unit power \leq 55 kW) 0.001 to 65.535 mH (drive unit power > 55 kW)	Auto-tuned	★
F1-19	Synchronous motor back EMF	0.1 to 6553.5 V	Auto-tuned	★
F1-23	Friction torque (percentage)	0.00% to 100.00%	0.00%	★

Para. No.	Para. Name	Setting Range	Default	Property
F1-24	Encoder feedback speed (U0-29) display filtering	0 to 65535 ms	0	☆
F1-25	Encoder power supply selection	0: 15 V power supply 1: 5 V power supply Note: Applied for dual-axis models only.	1	★
F1-26	Auto-tuning direction (inertia and synchronous motor auto-tuning)	0 to 1	1	★
F1-27	Encoder pulses per revolution	1 to 20000	1024	★
F1-28	Encoder type	0: ABZ incremental encoder 1: 23-bit encoder 2: Resolver	0	★
F1-29	PG signal filter	0: Non-adaptive filter 1: Adaptive filter 2: Fixed interlock 3: Automatic interlock	1	★
F1-30	AB phase sequence of ABZ incremental encoder	0: Positive 1: Negative	0	★
F1-31	Encoder zero position angle	0.0° to 359.9°	0.0°	★
F1-32	Motor gear ratio (numerator)	1 to 65535	1	★
F1-33	Motor gear ratio (denominator)	1 to 65535	1	★
F1-34	Number of pole pairs of resolver	1 to 32		
F1-35	Frequency-division coefficient of resolver	0 to 63		
F1-36	PG card wire-breaking detection	0: Disabled 1: Enabled	1	★

Appendix A Parameter Table

Para. No.	Para. Name	Setting Range	Default	Property
F1-37	Auto-tuning selection	0: No operation 1: Asynchronous motor static auto-tuning 2: Asynchronous motor no-load complete auto-tuning 3: Asynchronous motor static complete auto-tuning 4: Asynchronous motor inertia auto-tuning (only FVC) 11: Synchronous motor no-load partial auto-tuning (back EMF exclusive) 12: Synchronous motor dynamic no-load auto-tuning 13: Synchronous motor static complete auto-tuning 14: Synchronous motor inertia auto-tuning (only FVC)	0	★
Group F2: 1st Motor Vector Control Parameters				
F2-00	Speed loop proportional gain Kp at low speed	1 to 200	Asynchronous motor: 30 Synchronous motor: 20	☆
F2-01	Speed loop integral time Ti at low speed	0.001s to 10.000s	0.500s	☆
F2-02	Switchover frequency 1	0.00 to switchover frequency 2 (F2-05)	5.00 Hz	☆
F2-03	Speed loop proportional gain Kp at high speed	1 to 200	20	☆
F2-04	Speed loop integral time Ti at high speed	0.001s to 10.000s	1.000s	☆
F2-05	Switchover frequency 2	F2-02 (Switchover frequency 1) to maximum frequency (F0-10)	10.00 Hz	☆
F2-06	SVC/FVC slip compensation gain	50% to 200%	100%	☆
F2-07	Speed feedback filter time	0.000s to 0.100s	0.004s	☆
F2-08	SVC/FVC deceleration over-excitation gain	0 to 200	64	☆

Para. No.	Para. Name	Setting Range	Default	Property
F2-09	Torque limit source in speed control (motoring)	0: Digital setting (F2-10) 1: AI1 2: AI2 4: Pulse reference (DIO1) 5: Communication setting 6: MIN (AI1, AI2) 7: MAX (AI1, AI2) 100% of the values 1 to 7 corresponding to F2-10.	0	☆
F2-10	Digital setting of torque limit in speed control (motoring)	0.0% to 200.0%	150.0%	☆
F2-11	Torque limit source in speed control (generating)	0: Digital setting (F2-10) 1: AI1 2: AI2 4: Pulse reference (DIO1) 5: Communication setting 6: MIN (AI1, AI2) 7: MAX (AI1, AI2) 8: Digital setting (F2-12)	0	☆
F2-12	Digital setting of torque limit in speed control (generating)	0.0% to 200.0%	150.0%	☆
F2-13	Current loop proportional gain Kp at low speed	0.1 to 10.0	1.0	☆
F2-14	Current loop integral gain Ki at low speed	0.1 to 10.0	1.0	☆
F2-15	Current loop proportional gain Kp at high speed	0.1 to 10.0	1.0	☆
F2-16	Current loop integral gain Ki at high speed	0.1 to 10.0	1.0	☆
F2-17	Speed loop proportional gain Kp at zero speed lock	1 to 100	30	☆
F2-18	Speed loop integral time Ti at zero speed lock	0.001s to 10.000s	0.500s	☆
F2-20	Speed loop switchover frequency at zero speed lock	0.00 to F2-02 (Switchover frequency 1)	0.05 Hz	☆
F2-21	Maximum output voltage coefficient	100 to 110	100	☆

Appendix A Parameter Table

Para. No.	Para. Name	Setting Range	Default	Property
F2-22	Output voltage filter time	0.000 to 0.010s	0.000s	☆
F2-23	Zero speed lock	0: Disabled 1: Enabled	0	★
F2-24	SVC/FVC overvoltage suppression coefficient KP	0 to 1000	40	☆
F2-25	Acceleration rate compensation gain	0 to 200	0	☆
F2-26	Acceleration rate compensation filter	0 to 500	10	☆
F2-27	SVC/FVC overvoltage suppression function	0: Disabled 1: Enabled	1	☆
F2-28	Cut-off frequency of torque filter	50 to 1000 Hz	500 Hz	☆
F2-29	Synchronous motor initial angle detection current	50% to 180%	80%	☆
F2-30	Speed loop parameter auto-calculation	0: Disabled 1: Enabled	0	★
F2-31	Expected speed loop bandwidth at high speed	1.0 to 200.0 Hz	10.0 Hz	☆
F2-32	Expected speed loop bandwidth at low speed	1.0 to 200.0 Hz	10.0 Hz	☆
F2-33	Expected speed loop bandwidth at zero speed	1.0 to 200.0 Hz	10.0 Hz	☆
F2-34	Expected speed loop damping ratio	0.100 to 65.000	1.000	☆
F2-35	System inertia (equivalent to startup time)	0.001s to 50.000s	Model dependent	★
F2-36	Single motor inertia ($\text{kg}\cdot\text{m}^2$)	0.001 to 50.000	Model dependent	★
F2-43	Inertia auto-tuning and dynamic speed reference (unit: 30%; base value: rated motor frequency)	0% to 100%	30%	★
F2-47	Inertia auto-tuning	0: Disabled 1: Enabled	0	★

Para. No.	Para. Name	Setting Range	Default	Property
F2-48	Speed loop bandwidth setting value in inertia auto-tuning (unit: Hz)	0.1 to 100.0	10.0 Hz	★
F2-50	Inertia auto-tuning mode	0: Acceleration/deceleration mode 1: Triangular wave mode	0	★
F2-51	Inertia auto-tuning acceleration/deceleration coefficient (unit: 0.1)	0.1 to 10.0	1.0	★
F2-52	Decoupling control	0: Disabled 1: Enabled	0	★
F2-53	Generating power limit function	0: Disabled 1: Enabled	0	★
F2-54	Generating power limit value	0.0 to 200.0%	Model dependent	★
Group F3: V/F Control Parameters				
F3-00	V/F curve setting	0: Linear V/F 1: Multi-point V/F 2: Square V/F 3: 1.2-power V/F 4: 1.4-power V/F 6: 1.6-power V/F 8: 1.8-power V/F 9: Reserved 10: V/F complete separation 11: V/F half separation	0	★
F3-01	Torque boost	0.0%: Fixed torque boost 0.1% to 30.0%	Model dependent	☆
F3-02	Cut-off frequency of torque boost	0.00 Hz to maximum frequency (F0-10)	50.00 Hz	★
F3-03	Multi-point V/F frequency 1	0.00 Hz to F3-05 (Multi-point V/F frequency 2)	0.00 Hz	★
F3-04	Multi-point V/F voltage 1	0.0% to 100.0%	0.0%	★
F3-05	Multi-point V/F frequency 2	F3-03 (Multi-point V/F frequency 1) to F3-07 (Multi-point V/F frequency 3)	0.00 Hz	★
F3-06	Multi-point V/F voltage 2	0.0% to 100.0%	0.0%	★
F3-07	Multi-point V/F frequency 3	F3-05 (Multi-point V/F frequency 2) to F1-04 (Rated motor frequency)	0.00 Hz	★
F3-08	Multi-point V/F voltage 3	0.0% to 100.0%	0.0%	★

Appendix A Parameter Table

Para. No.	Para. Name	Setting Range	Default	Property
F3-09	V/F slip compensation gain	0.0% to 200.0%	0.0%	☆
F3-10	V/F over-excitation gain	0 to 200	64	☆
F3-11	V/F oscillation suppression gain	0 to 100	Model dependent	☆
F3-12	Oscillation suppression gain function	0: Disabled 3: Enabled	3	★
F3-13	Voltage source for V/F separation	0: Digital setting (F3-14) 1: AI1 2: AI2 4: Pulse reference (DIO1) 5: Multi-reference	0	☆
F3-14	Digital setting of voltage for V/F separation	0 V to rated motor voltage (F1-02)	0 V	☆
F3-15	Voltage rise time of V/F separation	0.0s to 1000.0s It sets the time for the output voltage to rise from 0 to the rated motor voltage (F1-02).	0.0s	☆
F3-16	Voltage decline time of V/F separation	0.0s to 1000.0s It sets the time for the output voltage to rise from 0 to the rated motor voltage (F1-02).	0.0s	☆
F3-17	Stop mode selection for V/F separation	0: Frequency and voltage declining to 0 independently 1: Frequency declining after voltage declines to 0	0	★
F3-18	Current limit level	50% to 200%	150%	★
F3-19	Current limit selection	0: Disabled 1: Enabled	1	★
F3-20	Current limit gain	0 to 100	20	☆
F3-21	Compensation factor of speed multiplying current limit level	50 to 200	50	★
F3-22	Voltage limit	650.0 to 800.0 V	770.0 V	★
F3-23	Voltage limit selection	0: Disabled 1: Enabled	1	★
F3-24	Frequency gain for voltage limit	0 to 100	30	☆
F3-25	Voltage gain for voltage limit	0 to 100	30	☆

Para. No.	Para. Name	Setting Range	Default	Property
F3-26	Frequency rise threshold during voltage limit	0 to 50	5	★
F3-27	Slip compensation time constant	0.1 to 10.0	0.5	☆
F3-28	Automatic frequency rise function	0: Disabled 1: Enabled	0	★
F3-29	Minimum motoring torque current	10 to 100	50	★
F3-30	Maximum generating torque current	10 to 100	20	★
F3-31	Automatic frequency rise KP	0 to 100	50	☆
F3-32	Automatic frequency rise KI	0 to 100	50	☆
F3-33	Online torque compensation gain	80 to 150	100	★

Appendix A Parameter Table

Para. No.	Para. Name	Setting Range	Default	Property
Group F4: Input Terminals				
F4-00	DI1 function selection	0: No function 1: Forward RUN (FWD) 2: Reverse run (REV) 3: Three-wire control 4: Forward jog (FJOG) 5: Reverse jog (RJOG) 6: Terminal UP 7: Terminal DOWN 8: Coast to stop 9: Fault reset (RESET) 10: RUN disabled 11: External fault normally open (NO) input 12: Multi-reference terminal 1 13: Multi-reference terminal 2 14: Multi-reference terminal 3 15: Multi-reference terminal 4 16: Terminal 1 for acceleration/ deceleration time selection	1	★
F4-01	DI2 function selection	17: Terminal 2 for acceleration/ deceleration time selection 18: Frequency source switchover 19: UP and DOWN setting clear (terminal, operating panel) 20: Command source switchover 21: Acceleration/Deceleration inhibited 22: PID pause 23: PLC status reset 24: Wobble disabled 25: Counter input (DIO1) 26: Counter reset 27: Length count input (DIO1) 28: Length reset 29: Torque control inhibited 31: Reserved 32: Immediate DC injection braking 33: External fault normally closed (NC) input 34: Frequency modification enabled 35: PID operation direction reverse 36: External stop terminal 1 37: Command source switchover terminal 2 38: PID integral disabled (To be continued)	4	★

Para. No.	Para. Name	Setting Range	Default	Property
F4-02	Reserved	39: Switchover between main frequency reference and preset frequency reference 40: Switchover between auxiliary frequency reference and preset frequency 41: Reserved 42: Position lock enabled 43: PID parameter switchover 44: User-defined fault 1 45: User-defined fault 2 46: Speed control/Torque control switchover 47: Emergency stop	9	★
F4-03	DIO1 function selection	48: External stop terminal 2 49: Deceleration DC injection braking 50: Clear the current running time 51: Two-wire control/ Three-wire control switchover 52-53: Reserved	12	★
F4-04	DIO2 function selection	54: Winding diameter 55 to 56: Initial winding diameter 57: Pre-drive 58: Winding/Unwinding switchover 59: Winding diameter calculation disabled 60: Exiting tension mode 61: Speed limit direction (End)	13	★
F4-10	DI filter time	0.000s to 1.000s	0.010s	☆
F4-11	Terminal I/O control mode	0: Two-wire mode 1 1: Two-wire mode 2 2: Three-wire mode 1 3: Three-wire mode 2	0	★
F4-12	Terminal UP/DOWN change rate	0.001 to 65.535 Hz/s	1.000 Hz/s	☆
F4-13	AI curve 1 minimum input	-10.00 V to F4-15 (AI curve 1 maximum input)	-10.00 V	☆
F4-14	Corresponding percentage of AI curve 1 minimum input	-100.0% to +100.0%	-100.0%	☆
F4-15	AI curve 1 maximum input	F4-13 (AI curve 1 minimum input) to +10.00 V	10.00 V	☆
F4-16	Corresponding percentage of AI curve 1 maximum input	-100.0% to +100.0%	100.0%	☆

Appendix A Parameter Table

Para. No.	Para. Name	Setting Range	Default	Property
F4-17	AI1 filter time	0.00s to 10.00s	0.10s	☆
F4-18	AI curve 2 minimum input	0.00 V to F4-20 (AI curve 2 maximum input)	0.00 V	☆
F4-19	Corresponding percentage of AI curve 2 minimum input	-100.0% to +100.0%	0.0%	☆
F4-20	AI curve 2 maximum input	F4-18 (AI curve 2 minimum input) to +10.00 V	10.00 V	☆
F4-21	Corresponding percentage of AI curve 2 maximum input	-100.0% to +100.0%	100.0%	☆
F4-22	AI2 filter time	0.00s to 10.00s	0.10s	☆
F4-23	AI curve 3 minimum input	0.00 V to F4-25 (AI curve 3 maximum input)	0.00 V	☆
F4-24	Corresponding percentage of AI curve 3 minimum input	-100.0% to +100.0%	0.0%	☆
F4-25	AI curve 3 maximum input	F4-23 (AI curve 3 minimum input) to 10.00 V	10.00 V	☆
F4-26	Corresponding percentage of AI curve 3 maximum input	-100.0% to +100.0%	100.0%	☆
F4-28	Pulse minimum input	0.00 kHz to F4-30 (Pulse max. input)	0.00 kHz	☆
F4-29	Corresponding percentage of AI minimum input	-100.0% to 100.0%	0.0%	☆
F4-30	Pulse max. input	F4-28 (Pulse minimum input) to 100.00 kHz	50.00 kHz	☆
F4-31	Corresponding percentage of pulse maximum input	-100.0% to 100.0%	100.0%	☆
F4-32	Pulse filter time	0.00s to 10.00s	0.10s	☆

Para. No.	Para. Name	Setting Range	Default	Property
F4-33	AI curve selection	Ones: AI1 curve selection 1: Curve 1 (2 points, see F4-13 to F4-16) 2: Curve 2 (2 points, see F4-18 to F4-21) 3: Curve 3 (2 points, see F4-23 to F4-26) 4: Curve 4 (4 points, see A6-00 to A6-07) 5: Curve 5 (4 points, see A6-08 to A6-15) Tens: AI2 curve selection (same as the ones position) Hundreds: Reserved	321	☆
F4-34	Setting for AI less than minimum input	Ones: Setting selection when AI1 less than min. input 0: Corresponding percentage of min. input 1: 0.0% Tens: Setting selection when AI2 less than min. input (same as the ones position) Hundreds: Reserved	0	☆
F4-35	DI1 delay	0.0s to 3600.0s	0.0s	☆
F4-36	DI2 delay	0.0s to 3600.0s	0.0s	☆
F4-37	Reserved	-	-	-
F4-38	DI active mode selection 1	0: High level active 1: Low level active Ones: DI1 Tens: DI2 Hundreds: Reserved Thousands: DIO1 Ten thousands: DIO2	0	★
F4-40	AI2 input type	0: Voltage input 1: Current input (input impedance 500 Ω)	0	★
F4-41	DIO terminal type	Ones: DIO1 type 0: DI/PulseIn 1: DO Tens: DIO2 type 0: DI 1: DO/FMP	00	★
Group F5: Output Terminals				
F5-00	DIO2 terminal output mode	0: Pulse output (FMP) 1: Digital output (FMR)	0	☆

Appendix A Parameter Table

Para. No.	Para. Name	Setting Range	Default	Property
F5-01	FMR output function selection	0: No function 1: AC drive running 2: Fault output 1 (immediate output in coast to stop mode, output after stop in decelerate to stop mode) 3: Frequency-level detection 1 output 4: Frequency reached 5: Zero-speed running (no output at stop) 6: Motor overload pending 7: AC drive overload pending 8: Set count value reached 9: Designated count value reached 10: Length reached 11: PLC cycle completed 12: Accumulative running time reached 13: Frequency limited 14: Torque limited 15: Ready for RUN 16: AI1 > AI2 17: Frequency upper limit reached 18: Frequency lower limit reached (no output at stop) 19: Undervoltage state output 20: Communication setting 23: Zero-speed running 2 (having output at stop) 24: Accumulative power-on time reached 25: Frequency-level detection 2 output 26: Frequency 1 reached 27: Frequency 2 reached 28: Current 1 reached 29: Current 2 reached 30: Timing reached 31: AI1 input limit exceeded 32: Drive output load loss 33: Reverse running 34: Zero current state 35: IGBT temperature reached 36: Output current limit exceeded (To be continued)	0	☆
F5-02	Relay function selection	17: Frequency upper limit reached 18: Frequency lower limit reached (no output at stop) 19: Undervoltage state output 20: Communication setting 23: Zero-speed running 2 (having output at stop) 24: Accumulative power-on time reached 25: Frequency-level detection 2 output 26: Frequency 1 reached 27: Frequency 2 reached 28: Current 1 reached 29: Current 2 reached 30: Timing reached 31: AI1 input limit exceeded 32: Drive output load loss 33: Reverse running 34: Zero current state 35: IGBT temperature reached 36: Output current limit exceeded (To be continued)	2	☆

Para. No.	Para. Name	Setting Range	Default	Property
F5-04	DIO1 function selection	37: Frequency lower limit reached (having output at stop) 38: Abnormality output (direct output at fault or warning) 39: Motor overheat pre-warning 40: Current running time reached 41: Fault output 2 (output at coast to stop/decelerate to stop, no output at undervoltage) 43: Position lock enabled (deviation pulses < F6-25) (End)	0	☆
F5-06	FMP output function selection	0: Running frequency 1: Set frequency 2: Output current 3: Output torque (100.0% corresponds to 2 times of rated motor torque) 4: Output power 5: Output voltage (100.0% corresponds to 1.2 times of rated drive voltage) 6: Pulse input (100.0% corresponds to 50.0 kHz)	0	☆
F5-07	AO function selection	7: AI1 8: AI2 9: Reserved 10: Length 11: Count value 12: Communication setting 13: Motor speed 14: Output current (100.0% corresponds to 1000.0 A) 15: Output voltage (100.0% corresponds to 1000.0 V) 16: Output torque (directional, 100.0% corresponds to 2 times of rated motor torque) 19: Taper output	0	☆
F5-09	Maximum FMP output frequency	0.01 to 100.00 kHz	50.00 kHz	☆
F5-10	AO1 zero offset coefficient	-100.0% to +100.0%	0.0%	☆
F5-11	AO gain	-10.00 to +10.00	1.00	☆
F5-17	FMR output delay	0.0s to 3600.0s	0.0s	☆

Appendix A Parameter Table

Para. No.	Para. Name	Setting Range	Default	Property
F5-18	Relay output delay	0.0s to 3600.0s	0.0s	☆
F5-20	DIO1 output delay	0.0s to 3600.0s	0.0s	☆
F5-22	DO active mode selection	0: Positive logic active 1: Negative logic active Ones: FMR (DIO2) Tens: Relay1 Hundreds: Reserved Thousands: DIO1 Ten thousands: Reserved	0	☆
F5-23	AO mode selection	0: Voltage output 1: Current output	0	★
Group F6: Start/Stop Control				
F6-00	Startup mode	0: Direct startup 1: Catching a spinning motor (AC asynchronous motor) 2: Pre-excited startup (AC asynchronous motor)	0	☆
F6-01	Mode of catching a spinning motor	0: From stop frequency 1: From 50 Hz 2: From maximum frequency	0	★
F6-02	Speed of catching a spinning motor	1 to 100	20	☆
F6-03	Startup frequency	0.00 to 10.00 kHz	0.00 Hz	☆
F6-04	Startup frequency active time	0.0s to 100.0s	0.0s	★
F6-05	Startup DC injection braking current	0% to 100%	0%	★
F6-06	Startup DC injection braking active time/ pre-excitation active time	0.0s to 100.0s	0.0s	★
F6-07	Acceleration/ Deceleration mode	0: Linear acceleration/deceleration 1: S-curve acceleration/deceleration	0	★
F6-08	Time proportion of S-curve start segment	0.0% to (100.0% – F6-09)	30.0%	★
F6-09	Time proportion of S-curve end segment	0.0% to (100.0% – F6-08)	30.0%	★
F6-10	Stop mode	0: Decelerate to stop 1: Coast to stop	0	☆
F6-11	Shutdown DC injection braking/ Zero servo start frequency	0.00 Hz to maximum frequency	0.00 Hz	☆

Para. No.	Para. Name	Setting Range	Default	Property
F6-12	Shutdown DC injection braking delay time	0.0s to 100.0s	0.0s	☆
F6-13	Shutdown DC injection braking current	0% to 100%	0%	☆
F6-14	Shutdown DC injection braking active time	0.0s to 100.0s	0.0s	☆
F6-15	Braking use ratio	0% to 100%	100%	★
F6-16	Closed-loop current KP of catching a spinning motor	0 to 1000	500	☆
F6-17	Closed-loop current KI of catching a spinning motor	0 to 1000	800	☆
F6-18	Current of catching a spinning motor	30 to 200	100	☆
F6-19	Torque feedforward set value	0.0% to 100.0%	0.0%	☆
F6-20	Voltage rise time at catching a spinning motor	0.5s to 3.0s	1.0s	☆
F6-21	Demagnetization time	00.00s to 10.00s	1.00s	☆
F6-22	Startup pre-torque setting	000.0% to 200.0%	0.0%	☆
F6-23	Operation at command from power supply unit	0: Stop according to stop mode (F6-10) 1: Ignore stop command	0	★
F6-24	Position lock KP	0.0 to 100.0	10.0	☆
F6-25	Position lock end amplitude	0 to 16383	10	☆

Appendix A Parameter Table

Para. No.	Para. Name	Setting Range	Default	Property
Group F7: Operating panel and Display				
F7-03	LED display running parameter 1	0000 to FFFF Bit00: Running frequency (Hz) Bit01: Frequency reference (Hz) Bit02: Bus voltage (V) Bit03: Output voltage (V) Bit04: Output Current (A) Bit05: Output power (kW) Bit06: Output torque (%) Bit07: DI input status Bit08: DO status Bit09: AI1 voltage (V) Bit10: AI2 voltage (V) Bit11: Reserved Bit12: Count value Bit13: Length value Bit14: Load speed display Bit15: PID reference	1F	☆
F7-04	LED display running parameters 2	0000 to FFFF Bit00: PID feedback Bit01: PLC stage Bit02: Pulse reference frequency (kHz) Bit03: Running frequency (Hz) Bit04: Remaining running time Bit05: AI1 voltage before correction (V) Bit06: AI2 voltage before correction (V) Bit07: Reserved Bit08: Linear speed Bit09: Current power-on time (hour) Bit10: Current running time (min) Bit11: Pulse reference frequency (Hz) Bit12: Communication setting value Bit13: Encoder feedback speed (Hz) Bit14: Main frequency display (Hz) Bit15: Auxiliary frequency display (Hz)	0	☆

Para. No.	Para. Name	Setting Range	Default	Property
F7-05	LED display stop parameters	0000 to FFFF Bit00: Frequency reference (Hz) Bit01: Bus voltage (V) Bit02: DI state Bit03: DO state Bit04: AI1 voltage (V) Bit05: AI2 voltage (V) Bit06: Reserved Bit07: Count value Bit08: Length value Bit09: PLC stage Bit10: Load speed Bit11: PID reference Bit12: Pulse input frequency (kHz)	33	☆
F7-06	Load speed display coefficient	0.0001 to 6.5000	1	☆
F7-07	Heatsink temperature of IGBT	0.0° C to 100.0° C	-	●
F7-08	Product series	810	-	●
F7-09	Accumulative running time	0 to 65535h	-	●
F7-10	Performance software version	-	-	●
F7-11	Function software version	-	-	●
F7-12	Number of decimal places for load speed display	0: 0 decimal places 1: 1 decimal place 2: 2 decimal places 3: 3 decimal places	1	☆
F7-13	Accumulative power-on time	0 to 65535 h	-	●
F7-14	Accumulative power consumption	0° to 65535°	-	●
Group F8: Auxiliary Functions				
F8-00	Jog running frequency	0.00 Hz to maximum frequency (F0-10)	2.00 Hz	☆
F8-01	Jog acceleration time	0.0s to 6500.0s	20.0s	☆
F8-02	Jog deceleration time	0.0s to 6500.0s	20.0s	☆
F8-03	Acceleration time 2	0.0s to 6500.0s	Model dependent	☆
F8-04	Deceleration time 2	0.0s to 6500.0s	Model dependent	☆
F8-05	Acceleration time 3	0.0s to 6500.0s	Model dependent	☆

Appendix A Parameter Table

Para. No.	Para. Name	Setting Range	Default	Property
F8-06	Deceleration time 3	0.0s to 6500.0s	Model dependent	☆
F8-07	Acceleration time 4	0.0s to 6500.0s	Model dependent	☆
F8-08	Deceleration time 4	0.0s to 6500.0s	Model dependent	☆
F8-09	Frequency jump 1	0.00 Hz to maximum frequency (F0-10)	0.00 Hz	☆
F8-10	Frequency jump2	0.00 Hz to maximum frequency (F0-10)	0.00 Hz	☆
F8-11	Frequency jump band	0.00 Hz to maximum frequency (F0-10)	0.00 Hz	☆
F8-12	Forward/Reverse run switchover dead-zone time	0.0s to 3000.0s	0.0s	☆
F8-13	Reverse run control	0: Enabled 1: Disabled	0	☆
F8-14	Running mode when frequency reference lower than frequency lower limit	0: Run at frequency lower limit 1: Stop 2: Run at zero speed	0	☆
F8-16	Accumulative power-on time threshold	0 to 65000h	0h	☆
F8-17	Accumulative running time threshold	0 to 65000h	0h	☆
F8-18	Startup protection	0: Disabled 1: Enabled	0	☆
F8-19	Frequency detection value 1 (FDT1)	0.00 Hz to maximum frequency (F0-10)	50.00 Hz	☆
F8-20	Frequency detection hysteresis 1 (FDT1)	0.0% to 100.0% (FDT1 level)	5.0%	☆
F8-21	Detection width of target frequency reached	0.0% to 100.0% (maximum frequency F0-10)	0.0%	☆
F8-22	Jump frequency during acceleration/ deceleration	0: Disabled 1: Enabled	0	☆
F8-25	Switchover frequency of acceleration time 1 and acceleration time 2	0.00 Hz to maximum frequency (F0-10)	0.00 Hz	☆
F8-26	Switchover frequency of deceleration time 1 and deceleration time 2	0.00 Hz to maximum frequency (F0-10)	0.00 Hz	☆
F8-27	Set highest priority to JOG function	0: Disabled 1: Enabled	0	☆

Para. No.	Para. Name	Setting Range	Default	Property
F8-28	Frequency detection value 2	0.00 Hz to maximum frequency (F0-10)	50.00 Hz	☆
F8-29	Frequency detection hysteresis 2	0.0% to 100.0%	5.0%	☆
F8-30	Detection value 1 of frequency	0.00 Hz to maximum frequency (F0-10)	50.00 Hz	☆
F8-31	Detection width 1 of frequency	0.0% to 100.0% (maximum frequency F0-10)	0.0%	☆
F8-32	Detection value 2 of frequency	0.00 Hz to maximum frequency (F0-10)	50.00 Hz	☆
F8-33	Detection width 2 of frequency	0.0% to 100.0% (maximum frequency F0-10)	0.0%	☆
F8-34	Zero current detection level	0.0% to 300.0% (rated motor current)	5.0%	☆
F8-35	Zero current detection delay	0.01s to 600.00s	0.10s	☆
F8-36	Output overcurrent threshold	0.0% (no detection) 0.1% to 300.0% (rated motor current)	200.0%	☆
F8-37	Output overcurrent detection delay	0.00s to 600.00s	0.00s	☆
F8-38	Detection value 1 of any current reached	0.0% to 300.0% (rated motor current)	100.0%	☆
F8-39	Detection width 1 of any current reached	0.0% to 300.0% (rated motor current)	0.0%	☆
F8-40	Detection value 2 of any current reached	0.0% to 300.0% (rated motor current)	100.0%	☆
F8-41	Detection width 2 of any current reached	0.0% to 300.0% (rated motor current)	0.0%	☆
F8-42	Timing function	0: Disabled 1: Enabled	0	★
F8-43	Timing duration source	0: Set by F8-44 1: AI1 2: AI2 100% of analog input corresponds to the value of F8-44	0	★
F8-44	Timing duration	0.0 to 6500.0 min	0.0 min	★
F8-45	AI1 input voltage lower limit	0.00 V to F8-46 (AI1 input voltage upper limit)	3.10 V	☆
F8-46	AI1 input voltage upper limit	F8-45 (AI1 input voltage lower limit) to 11.00 V	6.80 V	☆
F8-47	IGBT temperature threshold	0° C to 100° C	75° C	☆

Appendix A Parameter Table

Para. No.	Para. Name	Setting Range	Default	Property
F8-48	Cooling fan working mode	0: Working during drive running 1: Working continuously	0	☆
F8-49	Wakeup frequency	Hibernating frequency (F8-51) to maximum frequency (F0-10)	0.00 Hz	☆
F8-50	Wakeup delay	0.0s to 6500.0s	0.0s	☆
F8-51	Hibernating frequency	0.00 Hz to wakeup frequency (F8-49)	0.00 Hz	☆
F8-52	Hibernating delay	0.0s to 6500.0s	0.0s	☆
F8-53	Current running time threshold	0.0 to 6500.0 min	0.0 min	☆
F8-54	STO function	0: Disabled 1: Enabled	0	☆
F8-55	Emergency stop deceleration time	0.0s to 6500.0s	0.0	☆
F8-56	Jog by LED panel	-	-	☆
Group F9: Fault and Protection				
F9-00	AC drive overload protection	0: Disabled 1: Enabled	0	☆
F9-01	Motor overload protection gain	0.20 to 10.00	1.00	☆
F9-02	Motor overload pre-warning coefficient	50% to 100%	80%	☆
F9-06	Output phase loss detection before startup	0: Disabled 1: Enabled	0	☆
F9-07	Detection of short-circuit to ground	0: No detection 1: Detection before power-on 2: During running 3: Detection before power-on and during running	1	★
F9-09	Fault auto reset times	0 to 20	0	☆
F9-10	DO action during fault auto reset	0: Not act 1: Act	0	☆
F9-11	Auto fault reset interval	0.1s to 100.0s	1.0s	☆

Para. No.	Para. Name	Setting Range	Default	Property
F9-14	1st fault type	0: No fault 1: Hardware fault 2: Overcurrent during acceleration 3: Overcurrent during deceleration 4: Overcurrent at constant speed 5: Overvoltage during acceleration 6: Overvoltage during deceleration 7: Overvoltage at constant speed 9: Undervoltage 10: AC drive overload	-	●
F9-15	2nd fault type	11: Motor overload 12: Reserved 13: Output phase loss 14: IGBT overheat 15: External device fault 16: Communication fault 17: Reserved 18: Reserved 19: Motor auto-tuning abnormal 20: Encoder/PG card abnormal 21: EEPROM read/write error 22: Motor auto-tuning abnormal 23: Motor short circuit to ground	-	●
F9-16	3rd (latest) fault type	24: Inter-phase short-circuit 25: Power supply unit fault 26: Accumulative running time reached 27: User-defined fault 1 28: User-defined fault 2 29: Accumulative power-on time reached 30: Load loss 31: PID feedback loss during running 42: Speed deviation excessive 43: Motor overspeed 45: Motor overtemperature 80: Fan fault	-	●
F9-17	Frequency upon 3rd fault	0.00 to 655.35 Hz	0.00 Hz	●
F9-18	Current upon 3rd fault	0.00 to 655.35 A	0.00 A	●
F9-19	Bus voltage upon 3rd fault	0.0 to 6553.5 V	0.0 V	●
F9-20	DI status upon 3rd fault	0 to 9999	0	●
F9-21	Output terminal status upon 3rd fault	0 to 9999	0	●

Appendix A Parameter Table

Para. No.	Para. Name	Setting Range	Default	Property
F9-22	AC drive status upon 3rd fault	0 to 65535	0	●
F9-23	Power-on time upon 3rd fault	0s to 65535s	0s	●
F9-24	Running time upon 3rd fault	0.0s to 6553.5s	0.0s	●
F9-25	IGBT temperature upon 3rd fault			●
F9-26	3rd fault subcode			●
F9-27	Frequency upon 2nd fault	0.00 Hz to 655.35 Hz	0.00 Hz	●
F9-28	Current upon 2nd fault	0.00 A to 655.35 A	0.00 A	●
F9-29	Bus voltage upon 2nd fault	0.0 V to 6553.5 V	0.0 V	●
F9-30	DI status upon 2nd fault	0 to 9999	0	●
F9-31	Output terminal status upon 2nd fault	0 to 9999	0	●
F9-32	AC drive status upon 2nd fault	0 to 65535	0	●
F9-33	Power-on time upon 2nd fault	0s to 65535s	0s	●
F9-34	Running time upon 2nd fault	0.0s to 6553.5s	0.0s	●
F9-35	IGBT temperature upon 2nd fault			●
F9-36	2nd fault subcode			●
F9-37	Frequency upon 1st fault	0.00 Hz to 655.35 Hz	0.00 Hz	●
F9-38	Current upon 1st fault	0.00 A to 655.35 A	0.00 A	●
F9-39	Bus voltage upon 1st fault	0.0 V to 6553.5 V	0.0 V	●
F9-40	Input terminal status upon 1st fault	0 to 9999	0	●
F9-41	Output terminal status upon 1st fault	0 to 9999	0	●
F9-42	AC drive status upon 1st fault	0 to 65535	0	●
F9-43	Power-on time upon 1st fault	0s to 65535s	0s	●
F9-44	Running time upon 1st fault	0.0s to 6553.5s	0.0s	●

Para. No.	Para. Name	Setting Range	Default	Property
F9-45	IGBT temperature upon 1st fault	-	-	●
F9-46	1st fault subcode	-	-	●
F9-48	Fault protection action selection 1	Ones: Motor overload (E11) Tens: Reserved Thousands: Power output phase loss (E13) Thousands: Heatsink overheat (E14) Ten thousands: External device fault (E15) Note: For "Power output phase loss", "Decelerate to stop" or "Warning" is valid only for V/F control.	10050	★
F9-49	Fault protection action selection 2	Ones: Communication timeout (E16) Tens: External DC soft charge unit fault (E17) (only applicable for 90 kW or higher models) Hundreds: Reserved Thousands: Motor auto-tuning fault (E19) Ten thousands: Encoder fault (E20)	00050	★
F9-50	Fault protection action selection 3	Ones: EEPROM read/write fault (E21) Tens: Motor auto-tuning result abnormal (E22) Hundreds: Motor short-circuit to ground (E23) Thousands: Inter-phase short circuit (E24) Ten thousands: Reserved	25000	★
F9-51	Fault protection action selection 4	Ones: Accumulative running time reached (E26) Tens: User-defined fault 1 (E27) Hundreds: User-defined fault 2 (E28) Thousands: Accumulative power-on time reached (E29) Ten thousands: Load loss (E30)	51111	★
F9-52	Fault protection action selection 5	Ones: PID feedback loss during running (E31) Tens: Reserved Hundreds: Reserved Thousands: Speed deviation excessive (E42) Ten thousands: Motor overspeed (E43)	00101	★

Appendix A Parameter Table

Para. No.	Para. Name	Setting Range	Default	Property
F9-53	Fault protection action selection 6	Ones: Motor overheat (E45) Tens: Reserved Hundreds: Reserved Thousands: Reserved Ten thousands: Fan fault (E80)	05500	★
F9-54	Frequency selection for continuing to run upon fault	0: Current running frequency 1: Frequency reference 2: Frequency upper limit 3: Frequency lower limit 4: Backup frequency upon abnormality	1	☆
F9-55	Backup frequency upon abnormality	0.0% to 100.0% (maximum frequency, F0-10)	100.0%	☆
F9-56	Type of motor temperature sensor	0: No temperature sensor (AI1 input) 1: PT100 2: PT1000	0	☆
F9-57	Motor overheat protection threshold	0° C to 200° C	110°C	☆
F9-58	Motor overheat pre-warning threshold	0° C to 200° C	90°C	☆
F9-59	Power dip ride-through function selection	0: Disabled 1: Decelerate 2: Decelerate to stop	0	★
F9-60	Threshold of power dip ride- through function disabled	80 to 100%	85%	☆
F9-61	Judging time of bus voltage recovering from power dip	0.0s to 100.0s	0.5s	☆
F9-62	Threshold of power dip ride- through function enabled	60% to 100% (standard bus voltage)	80%	☆
F9-64	Load loss detection level	0.0 to 100.0%	10.0%	☆
F9-65	Load loss detection time	0.1s to 60.0s	1.0s	☆
F9-67	Overspeed detection level	0.0% to 50.0% (maximum frequency, F0-10) 0.0%: no detection	5.0%	☆
F9-68	Overspeed detection time	0.0s to 60.0s	1.0s	☆

Para. No.	Para. Name	Setting Range	Default	Property
F9-69	Detection level of speed deviation excessive	0.0% to 50.0% (maximum frequency, F0-10) 0.0%: No detection	20.0%	☆
F9-70	Detection time of speed deviation excessive	0.0s to 60.0s	5.0s	☆
F9-71	Power dip ride-through gain	0 to 100	40	☆
F9-72	Power dip ride-through integral coefficient	0 to 100	30	☆
F9-73	Deceleration time of power dip ride-through	0.0 to 300.0s	20.0s	☆
Group FA: Process Control PID Function				
FA-00	PID reference setting channel	0: FA-01 1: AI1 2: AI2 4: Pulse reference (DIO1) 5: Communication setting 6: Multi-reference	0	☆
FA-01	PID digital setting	0.0% to 100.0%	50.0%	☆
FA-02	PID feedback setting channel	0: AI1 1: AI2 3: AI1 – AI2 4: Pulse reference (DIO1) 5: Communication setting 6: AI1 + AI2 7: MAX (AI1, AI2) 8: MIN (AI1, AI2)	0	☆
FA-03	PID operation direction	0: Forward 1: Reverse	0	☆
FA-04	PID reference and feedback range	0 to 65535	1000	☆
FA-05	Proportional gain Kp1	0.0 to 1000.0	20.0	☆
FA-06	Integral time Ti1	0.01s to 100.00s	2.00s	☆
FA-07	Differential time Td1	0.000s to 10.000s	0.000s	☆
FA-08	PID output limit in reverse direction	0.00 Hz to maximum frequency (F0-10)	2.00 Hz	☆
FA-09	PID deviation limit	0.0% to 100.0%	0.0%	☆
FA-10	PID differential limit	0.00% to 100.00%	0.10%	☆
FA-11	PID reference change time	0.00 to 650.00s	0.00s	☆
FA-12	PID feedback filter time	0.00 to 60.00s	0.00s	☆
FA-13	PID deviation gain	0.0% to 100.0%	100.0%	☆

Appendix A Parameter Table

Para. No.	Para. Name	Setting Range	Default	Property
FA-15	Proportional gain Kp2	0.0 to 1000.0	20.0	☆
FA-16	Integral time Ti2	0.01s to 100.00s	2.00s	☆
FA-17	Differential time Td2	0.000s to 10.000s	0.000s	☆
FA-18	PID parameter switchover condition	0: Not switchover 1: Switchover via DI 2: Auto switchover based on PID deviation 3: Auto switchover based on running frequency 6: Auto adjust based in winding diameter 7: Adjust based on percentage of winding diameter	0	☆
FA-19	PID deviation 1 for auto switchover	0.0% to FA-20 (PID deviation 2 for auto switchover)	20.0%	☆
FA-20	PID deviation 2 for auto switchover	FA-19 (PID deviation 1 for auto switchover) to 100.0%	80.0%	☆
FA-21	PID initial value	0.0% to 100.0%	0.0%	☆
FA-22	PID initial value active time	0.00 to 650.00s	0.00s	☆
FA-23	Maximum deviation between two PID outputs in forward direction	0.00% to 100.00%	1.00%	☆
FA-24	Maximum deviation between two PID outputs in reverse direction	0.00% to 100.00%	1.00%	☆
FA-25	PID integral property	0: Disabled 1: Enabled	0	☆
FA-26	Detection level of PID feedback loss	0.0%: No detection 0.1% to 100.0%	0.0%	☆
FA-27	Detection time of PID feedback loss	0.0s to 20.0s	0.0s	☆
Group Fb: Wobble Function, Fixed Length, and Count				
Fb-00	Wobble setting mode	0: Relative to the central frequency 1: Relative to maximum frequency (F0-10)	0	☆
Fb-01	Wobble amplitude	0.0% to 100.0%	0.0%	☆
Fb-02	Wobble step	0.0% to 50.0%	0.0%	☆
Fb-03	Wobble cycle	0.1s to 3000.0s	10.0s	☆

Para. No.	Para. Name	Setting Range	Default	Property
Fb-04	Triangular wave rising time coefficient	0.1% to 100.0%	50.0%	☆
Fb-05	Set length	0 to 65535 m	1000 m	☆
Fb-06	Actual length	0 to 65535 m	0 m	☆
Fb-07	Number of pulses per meter	0.1 to 6553.5	100.0	☆
Fb-08	Set count value	1 to 65535	1000	☆
Fb-09	Designated count value	1 to 65535	1000	☆
Fb-10	Loop calculation reset method (loop calculation supported by only dual-axis models, Fb-10 to Fb-19)	0: Edge triggering 1: Electrical level trigger	0	☆
Fb-11	Loop calculation reset signal	0: Not reset 1: Reset	0	☆
Fb-12	Power fail save calculation	0: Disabled 1: Enabled	0	☆
Fb-13	Original value of loop calculation	0 to 65535 (Fb-18=0) 0.0 to 6553.5 (Fb-18=1)	0	☆
Fb-14	Multi-drive ratio (numerator)	1 to 65535	1	☆
Fb-15	Multi-drive ratio (denominator)	1 to 65535	1	☆
Fb-16	Actual running loop (FB-13)	0 to 65535 (Fb-18=0) 0 to 6553.5 (Fb-18=1)	0	●
Fb-17	Running loop	0 to 65535 (Fb-18=0) 0 to 6553.5 (Fb-18=1)	0	●
Fb-18	Loop calculation precision	0: 1 loop 1: 0.1 loop	0	☆
Fb-19	Loop calculation direction	0: Consistent direct 1: Reverse direction	0	☆
Group FC: Multi-Reference and Simple PLC Function				
FC-00	Reference 0	-100.0% to 100.0%	0.0%	☆
FC-01	Reference 1	-100.0% to 100.0%	0.0%	☆
FC-02	Reference 2	-100.0% to 100.0%	0.0%	☆
FC-03	Reference 3	-100.0% to 100.0%	0.0%	☆
FC-04	Reference 4	-100.0% to 100.0%	0.0%	☆
FC-05	Reference 5	-100.0% to 100.0%	0.0%	☆
FC-06	Reference 6	-100.0% to 100.0%	0.0%	☆
FC-07	Reference 7	-100.0% to 100.0%	0.0%	☆

Appendix A Parameter Table

Para. No.	Para. Name	Setting Range	Default	Property
FC-08	Reference 8	-100.0% to 100.0%	0.0%	☆
FC-09	Reference 9	-100.0% to 100.0%	0.0%	☆
FC-10	Reference 10	-100.0% to 100.0%	0.0%	☆
FC-11	Reference 11	-100.0% to 100.0%	0.0%	☆
FC-12	Reference 12	-100.0% to 100.0%	0.0%	☆
FC-13	Reference 13	-100.0% to 100.0%	0.0%	☆
FC-14	Reference 14	-100.0% to 100.0%	0.0%	☆
FC-15	Reference 15	-100.0% to 100.0%	0.0%	☆
FC-16	Simple PLC running mode	0: Stop after running one cycle 1: Keep final values after running one cycle 2: Repeat after running one cycle	0	☆
FC-17	Simple PLC retentive selection	Ones: Retentive at power down 0: No 1: Yes Tens: Retentive at stop 0: No 1: Yes	00	☆
FC-18	Running time of simple PLC reference 0	0.0s(h) to 6553.5s(h)	0.0s(h)	☆
FC-19	Acceleration/Deceleration time of simple PLC reference 0	0 to 3	0	☆
FC-20	Running time of simple PLC reference 1	0.0s(h) to 6553.5s(h)	0.0s(h)	☆
FC-21	Acceleration/ deceleration time of simple PLC reference 1	0 to 3	0	☆
FC-22	Running time of simple PLC reference 2	0.0s(h) to 6553.5s(h)	0.0s(h)	☆
FC-23	Acceleration/ deceleration time of simple PLC reference 2	0 to 3	0	☆
FC-24	Running time of simple PLC reference 3	0.0s(h) to 6553.5s(h)	0.0s(h)	☆
FC-25	Acceleration/ deceleration time of simple PLC reference 3	0 to 3	0	☆
FC-26	Running time of simple PLC reference 4	0.0s(h) to 6553.5s(h)	0.0s(h)	☆

Para. No.	Para. Name	Setting Range	Default	Property
FC-27	Acceleration/ deceleration time of simple PLC reference 4	0 to 3	0	☆
FC-28	Running time of simple PLC reference 5	0.0s(h) to 6553.5s(h)	0.0s(h)	☆
FC-29	Acceleration/ deceleration time of simple PLC reference 5	0 to 3	0	☆
FC-30	Running time of simple PLC reference 6	0.0s(h) to 6553.5s(h)	0.0s(h)	☆
FC-31	Acceleration/ deceleration time of simple PLC reference 6	0 to 3	0	☆
FC-32	Running time of simple PLC reference 7	0.0s(h) to 6553.5s(h)	0.0s(h)	☆
FC-33	Acceleration/ deceleration time of simple PLC reference 7	0 to 3	0	☆
FC-34	Running time of simple PLC reference 8	0.0s(h) to 6553.5s(h)	0.0s(h)	☆
FC-35	Acceleration/ deceleration time of simple PLC reference 8	0 to 3	0	☆
FC-36	Running time of simple PLC reference 9	0.0s(h) to 6553.5s(h)	0.0s(h)	☆
FC-37	Acceleration/ deceleration time of simple PLC reference 9	0 to 3	0	☆
FC-38	Running time of simple PLC reference 10	0.0s(h) to 6553.5s(h)	0.0s(h)	☆
FC-39	Acceleration/ deceleration time of simple PLC reference 10	0 to 3	0	☆
FC-40	Running time of simple PLC reference 11	0.0s(h) to 6553.5s(h)	0.0s(h)	☆
FC-41	Acceleration/ deceleration time of simple PLC reference 11	0 to 3	0	☆
FC-42	Running time of simple PLC reference 12	0.0s(h) to 6553.5s(h)	0.0s(h)	☆

Appendix A Parameter Table

Para. No.	Para. Name	Setting Range	Default	Property
FC-43	Acceleration/ deceleration time of simple PLC reference 12	0 to 3	0	☆
FC-44	Running time of simple PLC reference 13	0.0s(h) to 6553.5s(h)	0.0s(h)	☆
FC-45	Acceleration/ deceleration time of simple PLC reference 13	0 to 3	0	☆
FC-46	Running time of simple PLC reference 14	0.0s(h) to 6553.5s(h)	0.0s(h)	☆
FC-47	Acceleration/ deceleration time of simple PLC reference 14	0 to 3	0	☆
FC-48	Running time of simple PLC reference 15	0.0s(h) to 6553.5s(h)	0.0s(h)	☆
FC-49	Acceleration/ deceleration time of simple PLC reference 15	0 to 3	0	☆
FC-50	Time unit of simple PLC running	0: s (second) 1: h (hour)	0	☆
FC-51	Reference 0 source	0: FC-00 (Reference 0) 1: AI1 2: AI2 4: Pulse reference (DIO1) 5: PID 6: Set by preset frequency (F0-08), modified via terminal UP/DOWN	0	☆
Group Fd: Communication Parameters				
Fd-00	Modbus baud rate	0: 300 bps 1: 600 bps 2: 1,200 bps 3: 2,400 bps 4: 4,800 bps 5: 9,600 bps 6: 19,200 bps 7: 38,400 bps 8: 57,600 bps 9: 11,5200 bps	5	☆

Para. No.	Para. Name	Setting Range	Default	Property
Fd-01	Modbus data format	0: No check, data format <8,N,2> 1: Even parity check, data format <8,E,1> 2: Odd parity check, data format <8,O,1> 3: No check, data format <8,N,1>	0	☆
Fd-02	Modbus local address	0: Broadcast address; 1 to 247	1	☆
Fd-03	Modbus response delay	0 to 20 ms	2	☆
Fd-04	Modbus communication timeout	0.0s: invalid 0.1s to 60.0s	0	☆
Fd-06	Auto reset of communication fault	0: Disabled 1: Enabled	1	☆
Fd-07	Power supply unit and drive unit communication enable	0: Disabled 1: Enabled	1	★
Fd-09	Communication status	Ones (CANopen) 0: Disabled 1: Initiation 2: Pre-operational 8: Operational Tens (CANlink) 0: Disabled 1: Initiation 2: Pre-operational 8: Operational Hundreds (Profibus-DP) 0: Disabled 1: Initiation 2: Pre-operational 8: Operational	0	●
Fd-10	CANopen/CANlink switchover	1: CANopen 2: CANlink	1	★
Fd-11	CANopen402 protocol (reserved)	0: Disabled 1: Enabled	1	★
Fd-12	CAN baud rate	0: 20 Kbps 1: 50 Kbps 2: 100 Kbps 3: 125 Kbps 4: 250 Kbps 5: 500 Kbps 6: 1 Mbps	5	★
Fd-13	CAN station No.	1 to 127 (for both CANlink and CANopen)	1	★

Appendix A Parameter Table

Para. No.	Para. Name	Setting Range	Default	Property
Fd-14	Number of CAN frames received in a period	-	-	●
Fd-15	Maximum value of node receiving error counter	-	-	●
Fd-16	Maximum value of node sending error counter	-	-	●
Fd-17	CANopen/CANlink bus disconnection times in a period	-	-	●
Fd-18	Power supply unit No.	1 to 99	1	★
Fd-20	DP communication address	0: broadcast address, 1 to 125	0	★
Fd-21	DP communication dropping coefficient	0 to 65535	350	☆
Fd-22	DP-CANopen conversion network bridge	0: Reporting communication error reported if the number of slaves in PLC is inconsistent with the actual 1: Not reporting communication error reported if the number of slaves in PLC is inconsistent with the actual	0	☆
Fd-23	Number of online slaves	0 to 65535	0	●
Fd-24	DP-CANopen conversion power-on delay	0s to 65535s	8s	☆
Fd-25	Status of stations 1 to 15 at DP-CANopen conversion	0: Offline 1: Online Bit1: Station 1 Bit2: Station 2 ... Bit15: Station 15	0	●
Fd-26	Status of stations 16 to 30 at DP-CANopen conversion	0: Offline 1: Online Bit0: Station 16 Bit1: Station 17 ... Bit14: Station 30	0	●
Fd-33	CANopen communication period	-	-	●
Fd-94	Modbus software version	0.00 to 655.35	0.00	●
Fd-95	CANlink software version	0.00 to 655.35	0.00	●

Para. No.	Para. Name	Setting Range	Default	Property
Fd-96	CANopen software version	0.00 to 655.35	0.00	●
Fd-95	CANlink software version	0.00 to 655.35	0.00	●
Fd-96	CANopen software version	0.00 to 655.35	0.00	●
Fd-97	DP software version	0.00 to 655.35	0.00	●
Fd-98	DP2CANOPEN software version	-	-	●
Fd-99	MODBUS2CANOPEN software version	-	-	●
Group FE: User-defined parameters				
FE-00	User-defined parameter 0	F0-00 to FP-xx A0-00 to Ax-xx U0-xx to U0-xx	F0-01	☆
FE-01	User-defined parameter 1		F0-02	☆
FE-02	User-defined parameter 2		F0-03	☆
FE-03	User-defined parameter 3		F0-07	☆
FE-04	User-defined parameter 4		F0-08	☆
FE-05	User-defined parameter 5		F0-17	☆
FE-06	User-defined parameter 6		F0-18	☆
FE-07	User-defined parameter 7		F3-00	☆
FE-08	User-defined parameter 8		F3-01	☆
FE-09	User-defined parameter 9		F4-00	☆
FE-10	User-defined parameter 10		F4-01	☆
FE-11	User-defined parameter 11		F4-02	☆
FE-12	User-defined parameter 12		F5-04	☆
FE-13	User-defined parameter 13		F5-07	☆

Appendix A Parameter Table

Para. No.	Para. Name	Setting Range	Default	Property
FE-14	User-defined parameter 14	F0-00 to FP-xx A0-00 to Ax-xx U0-xx to U0-xx	F6-00	☆
FE-15	User-defined parameter 15		F6-10	☆
FE-16	User-defined parameter 16		F0-00	☆
FE-17	User-defined parameter 17		F0-00	☆
FE-18	User-defined parameter 18		F0-00	☆
FE-19	User-defined parameter 19		F0-00	☆
FE-20	User-defined parameter 20		F0-00	☆
FE-21	User-defined parameter 21		F0-00	☆
FE-22	User-defined parameter 22		F0-00	☆
FE-23	User-defined parameter 23		F0-00	☆
FE-24	User-defined parameter 24		F0-00	☆
FE-25	User-defined parameter 25		F0-00	☆
FE-26	User-defined parameter 26		F0-00	☆
FE-27	User-defined parameter 27		F0-00	☆
FE-28	User-defined parameter 28		F0-00	☆
FE-29	User-defined parameter 29		F0-00	☆
FE-30	User-defined parameter 30		F0-00	☆
FE-31	User-defined parameter 31		F0-00	☆
Group FP: Function Parameter Management				
FP-00	User Password	0 to 65535	0	☆

Para. No.	Para. Name	Setting Range	Default	Property
FP-01	Parameter initialization	0: No operation 01: Restore factory parameters except motor parameters, encoder parameters, and F0-10 (Maximum frequency) 02: Clear records 04: Back up current user parameters 501: Restore backup user parameters 502: Restore to factory setting (except FD group and AF group parameters) (supported by only dual-axis models)	0	★
FP-02	Parameter display property	Ones: Selection of display of group U 0: No display 1: Display Tens: Selection of display of group A 0: No display 1: Display	111	☆
FP-03	Selection of individualized parameter display	Ones: Selection of display of user-defined parameters 0: No display 1: Display Tens: Selection of display of user-modified parameters 0: No display 1: Display	11	☆
FP-04	Selection of parameter modification	0: Disabled 1: Enabled	0	☆
Group A0: Torque Control Parameters				
A0-00	Speed/Torque control selection	0: Speed control 1: Torque control	0	★
A0-01	Torque reference source in torque control	0: Digital setting (A0-03) 1: AI1 2: AI2 4: Pulse reference (DIO1) 5: Communication setting 6: MIN (AI1, AI2) 7: MAX (AI1, AI2) (100.0% of the value corresponds to the setting of A0-03)	0	★
A0-03	Torque digital setting	-200.0% to 200.0%	100.0%	☆
A0-04	Torque filter time	0 to 5.000s	0.000s	☆
A0-05	Speed limit digital setting	-120.0% to 120.0%	0.00%	☆

Appendix A Parameter Table

Para. No.	Para. Name	Setting Range	Default	Property
A0-07	Acceleration time (torque)	0.0s to 650.00s	1.00s	☆
A0-08	Deceleration time (torque)	0.0s to 650.00s	1.00s	☆
A0-09	Setting channel of speed limit	0: A0-05 1: Frequency reference	0	☆
A0-10	Speed limit offset	0 to F0-10 (Maximum frequency)	5.00 Hz	☆
A0-11	Effective mode of speed limit offset	0: Bi-directional offset effective 1: Uni-directional offset effective	0	★
A0-12	Acceleration time (frequency)	0.0s to 6500.0s	1.0s	☆
A0-13	Deceleration time (frequency)	0.0s to 6500.0s	1.0s	☆
A0-14	Torque mode switchover	0: No switchover 1: Switchover to speed control at stop 2: Target torque at stop being 0	1	★
Group A1: Virtual DI/DO				
A1-00	VDI1 function selection	Refer to F4-00	0	★
A1-01	VDI2 function selection	Refer to F4-00	0	★
A1-02	VDI3 function selection	Refer to F4-00	0	★
A1-03	VDI4 function selection	Refer to F4-00	0	★
A1-04	VDI5 function selection	Refer to F4-00	0	★
A1-05	VDI active state setting mode	0: Decided by A1-06 1: DO state 2: DI state Ones: VDI1 Tens: VDI2 Hundreds: VDI3 Thousands: VDI4 Ten thousands: VDI5	00000	★
A1-06	Selection of VDI active state	0: Inactive 1: Active Ones: VDI1 Tens: VDI2 Hundreds: VDI3 Thousands: VDI4 Ten thousands: VDI5	00000	☆
A1-07	Function selection for A11 used as DI	Refer to F4-00	0	★

Para. No.	Para. Name	Setting Range	Default	Property
A1-08	Function selection for AI2 used as DI	Refer to F4-00	0	★
A1-10	Active mode selection for AI used as DI	Ones: AI1 0: High level active 1: Low level active Tens: AI2 0: High level active 1: Low level active	00	★
Group A5: Control Optimization Parameters				
A5-00	DPWM switchover frequency upper limit	0.00 Hz to maximum frequency (F0-10)	12.00Hz	☆
A5-01	PWM modulation mode	0: Asynchronous modulation 1: Synchronous modulation	0	☆
A5-02	Dead zone compensation	0: Disabled 1: Enabled	1	★
A5-03	Random PWM depth	0: Random PWM invalid 1 to 10	0	☆
A5-04	Fast current limit	0: Disabled 1: Enabled	1 0 (asynchronous motor in SVC)	☆
A5-05	Sampling delay	1 to 13	5	☆
A5-06	Undervoltage threshold	60% to 140%	100.0%	☆
Group A6: AI Curve Setting				
A6-00	AI curve 4 minimum input	-10.00 V to A6-02 (AI curve 4 inflection 1 input)	0.00 V	☆
A6-01	Corresponding percentage of AI curve 4 minimum input	-100.0% to +100.0%	0.0%	☆
A6-02	AI curve 4 inflection 1 input	A6-00 (AI curve 4 minimum input) to A6-04 (AI curve 4 inflection 2 input)	3.00 V	☆
A6-03	Corresponding percentage of AI curve 4 inflection 1 input	-100.0% to +100.0%	30.0%	☆
A6-04	AI curve 4 inflection 2 input	A6-02 (AI curve 4 inflection 1 input) to A6-06 (AI curve 4 maximum input)	6.00 V	☆
A6-05	Corresponding percentage of AI curve 4 inflection 2 input	-100.0% to +100.0%	60.0%	☆

Appendix A Parameter Table

Para. No.	Para. Name	Setting Range	Default	Property
A6-06	AI curve 4 maximum input	A6-04 (AI curve 4 inflection 2 input) to +10.00 V	10.00 V	☆
A6-07	Corresponding percentage of AI curve 4 maximum input	-100.0% to +100.0%	100.0%	☆
A6-08	AI curve 5 minimum input	-10.00 V to A6-10 (AI curve 5 inflection 1 input)	-10.00 V	☆
A6-09	Corresponding percentage of AI curve 5 minimum input	-100.0% to +100.0%	-100.0%	☆
A6-10	AI curve 5 inflection 1 input	A6-08 (AI curve 5 minimum input) to A6-12 (AI curve 5 inflection 2 input)	-3.00 V	☆
A6-11	Corresponding percentage of AI curve 5 inflection 1 input	-100.0% to +100.0%	-30.0%	☆
A6-12	AI curve 5 inflection 2 input	A6-10 (AI curve 5 inflection 1 input) to A6-14 (AI curve 5 maximum input)	3.00 V	☆
A6-13	Corresponding percentage of AI curve 5 inflection 2 input	-100.0% to +100.0%	30.0%	☆
A6-14	AI curve 5 maximum input	A6-12 (AI curve 5 inflection 2 input) to 10.00 V	10.00 V	☆
A6-15	Corresponding percentage of AI curve 5 maximum input	-100.0% to +100.0%	100.0%	☆
A6-16	AI1 gain	-10.00 to +10.00	1.00	☆
A6-17	AI1 zero offset coefficient	-100.0% to +100.0%	0.0%	☆
A6-18	AI2 gain	-10.00 to +10.00	1.00	☆
A6-19	AI2 zero offset coefficient	-100.0% to +100.0%	0.0%	☆
A6-24	Jump point of AI1 input corresponding percentage	-100.0% to 100.0%	0.0%	☆
A6-25	Jump amplitude of AI1 input corresponding percentage	0.0% to 100.0%	0.5%	☆
A6-26	Jump point of AI2 input corresponding percentage	-100.0% to 100.0%	0.0%	☆

Para. No.	Para. Name	Setting Range	Default	Property
A6-27	Jump amplitude of AI2 input corresponding percentage	0.0% to 100.0%	0.5%	☆
Group A8: Synchronization Control				
A8-00	Local address	0: broadcast address, 1 to 124	1	★
A8-01	Baud rate	6: 1 Mbps	6	★
A8-02	Synchronization control communication timeout duration	0.0s to 10.0s	1.0s	☆
A8-10	Master/Slave selection in speed and position control	0: Disabled 1: Master 2: Slave 3: Middle node	0	★
A8-11	Synchronization mode selection	0: Speed Synchronization 1: Position synchronization	0	★
A8-12	Station number to master to be followed (set for slave)	1 to 124	1	★
A8-14	Slave configuration parameter	0: Not following master start/stop command 1: Following master start/stop command	1	★
A8-15	Acceleration time (slave)	0.0s to 100.0s	0.0s	☆
A8-16	Deceleration time (slave)	0.0s to 100.0s	0.0s	☆
A8-17	Electronic gear ratio (numerator)	1 to 65535	1	☆
A8-18	Electronic gear ratio (denominator)	1 to 65535	1	☆
A8-19	Speed feedforward gain	0.000 to 20.000	1.000	☆
A8-20	Position loop proportional gain switchover mode	0: Fixed at A8-21 1: Switchover based on deviation 2: Switchover based on frequency	0	☆
A8-21	Speed loop proportional gain 1	0.00 to 100.00	5.00	☆
A8-22	Deviation 1 for position loop proportional gain switchover	0 to A8-24 (Deviation 2 for position loop proportional gain switchover)	5	☆
A8-23	Position loop proportional gain 2	0.00 to 100.00	15	☆

Appendix A Parameter Table

Para. No.	Para. Name	Setting Range	Default	Property
A8-24	Deviation 2 for position loop proportional gain switchover	A8-22 to 60000	20	☆
A8-25	Speed proportional coefficient (slave) (reserved)	0.000 to 60.000	1.000	★
A8-26	Speed filter time	0.000s to 10.000s	0.000s	☆
A8-27	Acceleration rate compensation coefficient	0.00 to 100.00	5.00	☆
A8-28	Acceleration rate moving average filter coefficient	0 to 50	10	☆
A8-29	Minimum pulse deviation	0 to 500	0	☆
A8-30	Maximum pulse deviation	0 to 60000	500	☆
A8-31	Position loop output limit	0.00 to 600.00 Hz	2.00 Hz	☆
A8-32	Value detection of position error	0 to 60000	600	☆
A8-33	Time detection of position error	0.00 to 50.00 ms	1.00 ms	☆
A8-34	Speed/Position synchronization switchover mode	0: Not switchover 1: Switchover based on frequency	0	★
A8-35	Speed/Position synchronization switchover frequency	0.00 Hz to maximum frequency (F0-10)	50.00 Hz	★
A8-36	Communication delay compensation mode	0: Automatic compensation 1: Calculated based on baud rate 2: Parameter setting (A8-37)	0	★
A8-37	Communication delay setting	0 to 2000 us	156 us	★
A8-39	Frequency 1 for position loop proportional gain switchover	0.00 Hz to A8-40 (Frequency 2 for position loop proportional gain switchover)	5.00 Hz	☆
A8-40	Frequency 2 for position loop proportional gain switchover	A8-39 (Frequency 1 for position loop proportional gain switchover) to 600.00 Hz	10.00 Hz	☆

Para. No.	Para. Name	Setting Range	Default	Property
A8-42	Master sending frequency setting channel selection (set for master)	0: Feedback frequency 1: Running frequency	0	★
A8-43	Master sending frequency switchover threshold	0.00 to 600.00 kHz	5.00 Hz	★
A8-50	Master/Slave selection in load allocation	0: Disabled 1: Master 2: Slave	0	★
A8-52	Station number of master for synchronization (set for slave)	1 to 124	1	★
A8-54	Slave configuration parameter (load allocation)	0: Not following master start/stop command 1: Following master start/stop command	1	★
A8-55	Torque acceleration time	0.000s to 60.000s	0.000s	☆
A8-56	Torque deceleration time	0.000s to 60.000s	0.000s	☆
A8-57	Frequency gain	-10.00 to 10.00	1.00	★
A8-58	Frequency offset	-100.00% to 100.00%	0.00%	★
A8-59	Torque gain	-10.00 to 10.00	1.00	★
A8-60	Torque offset	-100.00% to 100.00%	0.00%	★
A8-61	Master sending frequency setting channel selection (set for master)	0: Feedback frequency 1: Running frequency 2: Running frequency if < A8-62, feedback frequency if > A8-62	0	☆
A8-62	Master sending frequency switchover threshold	0.00 to 600.00 Hz	5.00 Hz	☆
A8-70	Master/Slave selection in droop control	0: Disabled 1: Master 2: Slave 3: Auto droop	0	★
A8-71	Droop control mode selection	2: Master/Slave droop	2	★
A8-72	Synchronization master station number (effective for slave)	1 to 124	1	★

Appendix A Parameter Table

Para. No.	Para. Name	Setting Range	Default	Property
A8-74	Slave configuration parameter (droop control)	Ones 0: Not following master start/stop command 1: Following master start/stop command	1	★
A8-77	Droop ratio	0.00% to 15.00%	5.00%	☆
Group A9: Vector Control Parameters				
A9-00	Online auto-tuning of asynchronous motor rotor time constant	0: Disabled 1: Enabled	0	☆
A9-01	Rotor resistance gain by asynchronous motor auto-tuning in FVC mode	0 to 100	5	☆
A9-02	Start frequency for auto-tuning of asynchronous motor rotor resistance in FVC mode	2 to 100 Hz	7 Hz	☆
A9-03	Magnetic field coefficient by auto-tuning of asynchronous motor in FVC mode	30 to 150	40	☆
A9-04	Maximum torque limit coefficient of weaken flux field in SVC/FVC mode	30 to 150	80	☆
A9-05	Speed filter of asynchronous motor in SVC mode	5 to 32 ms	15 ms	☆
A9-06	Speed feedback operation of asynchronous motor speed control in SVC mode	0: No operation 1: Minimum synchronization frequency limited based on load change 2, 3: Fixed current output at low-speed running	0	☆
A9-07	Magnetic field adjusting band of asynchronous motor in SVC mode	0 to 8.0 Hz	2.0 Hz	☆
A9-08	Current at low-speed running of asynchronous motor in SVC mode	30 to 170	100	☆

Para. No.	Para. Name	Setting Range	Default	Property
A9-09	Switchover frequency of fixed current output of asynchronous motor in SVC mode	2.0 to 100.0Hz	3.0 Hz	☆
A9-10	Speed fluctuation suppression coefficient of asynchronous motor in SVC mode	0 to 6	3	☆
A9-11	Acceleration/Deceleration time of asynchronous motor in SVC mode	0.1s to 3000.0s	20.0s	☆
A9-12	Quick auto-tuning of stator resistance before asynchronous motor startup	0: Disabled 1: Enabled	0	☆
A9-13	Stator resistance coefficient 1 by asynchronous motor quick auto-tuning	-	-	★
A9-14	Stator resistance coefficient 2 by asynchronous motor quick auto-tuning	-	-	★
A9-15	Stator resistance coefficient 3 by asynchronous motor quick auto-tuning	-	-	★
A9-17	Real-time angle of synchronous motor	-	-	☆
A9-18	Initial position angle detection of synchronous motor	0: Detection always 1: No detection 2: Detection at first-time running	0	☆
A9-20	Weaken flux mode	0: Automatic 1: PMSM adjust voltage angle weaken flux 2: PMSM adjust axis D current (Id) weaken flux 3: Disabled	1	★
A9-21	Weaken flux gain of synchronous motor	0 to 50	5	☆
A9-22	Output voltage limit margin of synchronous motor	0% to 50%	5%	☆

Appendix A Parameter Table

Para. No.	Para. Name	Setting Range	Default	Property
A9-23	Maximum force gain of synchronous motor	20% to 300%	100%	☆
A9-24	Excitation current gain of synchronous motor	40% to 200%	100%	☆
A9-25	Speed evaluation integral gain of synchronous motor in SVC mode	5 to 1000	30	☆
A9-26	Speed evaluation proportional gain of synchronous motor in SVC mode	5 to 300	20	☆
A9-27	Speed filter of synchronous motor in SVC mode	10 to 2000	100	☆
A9-28	Minimum carrier frequency of synchronous motor in SVC mode	0.8 kHz to F0-15 (Carrier frequency)	2.0 kHz	☆
A9-29	Synchronous motor low-speed excitation current	0% to 80%	30%	☆
Group AC: AI/AO Correction				
AC-00	AI1 measured voltage 1	-10.000 to 10.000 V	Factory-corrected	☆
AC-01	AI1 displayed voltage 1	-10.000 to 10.000 V	Factory-corrected	☆
AC-02	AI1 measured voltage 2	-10.000 to 10.000 V	Factory-corrected	☆
AC-03	AI1 displayed voltage 2	-10.000 to 10.000 V	Factory-corrected	☆
AC-04	AI2 measured voltage 1	-10.000 to 10.000 V	Factory-corrected	☆
AC-05	AI2 displayed voltage 1	-10.000 to 10.000 V	Factory-corrected	☆
AC-06	AI2 measured voltage 2	-10.000 to 10.000 V	Factory-corrected	☆
AC-07	AI2 displayed voltage 2	-10.000 to 10.000 V	Factory-corrected	☆
AC-12	AO target voltage 1	-10.000 to 10.000 V	Factory-corrected	☆

Para. No.	Para. Name	Setting Range	Default	Property
AC-13	AO measured voltage 1	-10.000 to 10.000 V	Factory-corrected	☆
AC-14	AO target voltage 2	-10.000 to 10.000 V	Factory-corrected	☆
AC-15	AO measured voltage 2	-10.000 to 10.000 V	Factory-corrected	☆
AC-20	PT100 target voltage 1	-10.000 to 10.000 V	Factory-corrected	☆
AC-21	PT100 measured voltage 1	-3.300 to 3.300 V	Factory-corrected	☆
AC-22	PT100 target voltage 2	-3.300 to 3.300 V	Factory-corrected	☆
AC-23	PT100 measured voltage 2	-3.300 to 3.300 V	Factory-corrected	☆
AC-24	PT1000 target voltage 1	-3.300 to 3.300 V	Factory-corrected	☆
AC-25	PT1000 measured voltage 1	-3.300 to 3.300 V	Factory-corrected	☆
AC-26	PT1000 target voltage 2	-3.300 to 3.300 V	Factory-corrected	☆
AC-27	PT1000 measured voltage 2	-3.300 to 3.300 V	Factory-corrected	☆
AC-28	AO target current 1	0 to 20 mA	Factory-corrected	☆
AC-29	AO measured current 1	0 to 20 mA	Factory-corrected	☆
AC-30	AO target current 2	0 to 20 mA	Factory-corrected	☆
AC-31	AO measured current 2	0 to 20 mA	Factory-corrected	☆
Group AF: Process Data Address Mapping				
AF-00	RPDO1-SubIndex0-H	0x0000 to 0xFFFF	0x0000	☆
AF-01	RPDO1-SubIndex0-L	0x0000 to 0xFFFF	0x0000	☆
AF-02	RPDO1-SubIndex1-H	0x0000 to 0xFFFF	0x0000	☆
AF-03	RPDO1-SubIndex1- L	0x0000 to 0xFFFF	0x0000	☆
AF-04	RPDO1-SubIndex2-H	0x0000 to 0xFFFF	0x0000	☆
AF-05	RPDO1-SubIndex2- L	0x0000 to 0xFFFF	0x0000	☆
AF-06	RPDO1-SubIndex3-H	0x0000 to 0xFFFF	0x0000	☆
AF-07	RPDO1-SubIndex3- L	0x0000 to 0xFFFF	0x0000	☆
AF-08	RPDO2-SubIndex0-H	0x0000 to 0xFFFF	0x0000	☆

Appendix A Parameter Table

Para. No.	Para. Name	Setting Range	Default	Property
AF-09	RPDO2-SubIndex0- L	0x0000 to 0xFFFF	0x0000	☆
AF-10	RPDO2-SubIndex1-H	0x0000 to 0xFFFF	0x0000	☆
AF-11	RPDO2-SubIndex1- L	0x0000 to 0xFFFF	0x0000	☆
AF-12	RPDO2-SubIndex2-H	0x0000 to 0xFFFF	0x0000	☆
AF-13	RPDO2-SubIndex2- L	0x0000 to 0xFFFF	0x0000	☆
AF-14	RPDO2-SubIndex3-H	0x0000 to 0xFFFF	0x0000	☆
AF-15	RPDO2-SubIndex3- L	0x0000 to 0xFFFF	0x0000	☆
AF-16	RPDO3-SubIndex0-H	0x0000 to 0xFFFF	0x0000	☆
AF-17	RPDO3-SubIndex0- L	0x0000 to 0xFFFF	0x0000	☆
AF-18	RPDO3-SubIndex1-H	0x0000 to 0xFFFF	0x0000	☆
AF-19	RPDO3-SubIndex1- L	0x0000 to 0xFFFF	0x0000	☆
AF-20	RPDO3-SubIndex2-H	0x0000 to 0xFFFF	0x0000	☆
AF-21	RPDO3-SubIndex2- L	0x0000 to 0xFFFF	0x0000	☆
AF-22	RPDO3-SubIndex3-H	0x0000 to 0xFFFF	0x0000	☆
AF-23	RPDO3-SubIndex3- L	0x0000 to 0xFFFF	0x0000	☆
AF-24	RPDO4-SubIndex0-H	0x0000 to 0xFFFF	0x0000	☆
AF-25	RPDO4-SubIndex0- L	0x0000 to 0xFFFF	0x0000	☆
AF-26	RPDO4-SubIndex1-H	0x0000 to 0xFFFF	0x0000	☆
AF-27	RPDO4-SubIndex1- L	0x0000 to 0xFFFF	0x0000	☆
AF-28	RPDO4-SubIndex2-H	0x0000 to 0xFFFF	0x0000	☆
AF-29	RPDO4-SubIndex2- L	0x0000 to 0xFFFF	0x0000	☆
AF-30	RPDO4-SubIndex3-H	0x0000 to 0xFFFF	0x0000	☆
AF-31	RPDO4-SubIndex3- L	0x0000 to 0xFFFF	0x0000	☆
AF-32	TPDO1-SunIndex0-H	0x0000 to 0xFFFF	0x0000	☆
AF-33	TPDO1-SunIndex0-L	0x0000 to 0xFFFF	0x0000	☆
AF-34	TPDO1-SunIndex1-H	0x0000 to 0xFFFF	0x0000	☆
AF-35	TPDO1-SunIndex1-L	0x0000 to 0xFFFF	0x0000	☆
AF-36	TPDO1-SunIndex2-H	0x0000 to 0xFFFF	0x0000	☆
AF-37	TPDO1-SunIndex2-L	0x0000 to 0xFFFF	0x0000	☆
AF-38	TPDO1-SunIndex3-H	0x0000 to 0xFFFF	0x0000	☆
AF-39	TPDO1-SunIndex3-L	0x0000 to 0xFFFF	0x0000	☆
AF-40	TPDO2-SunIndex0-H	0x0000 to 0xFFFF	0x0000	☆
AF-41	TPDO2-SunIndex0-L	0x0000 to 0xFFFF	0x0000	☆
AF-42	TPDO2-SunIndex1-H	0x0000 to 0xFFFF	0x0000	☆
AF-43	TPDO2-SunIndex1-L	0x0000 to 0xFFFF	0x0000	☆
AF-44	TPDO2-SunIndex2-H	0x0000 to 0xFFFF	0x0000	☆

Para. No.	Para. Name	Setting Range	Default	Property
AF-45	TPDO2-SunIndex2-L	0x0000 to 0xFFFF	0x0000	☆
AF-46	TPDO2-SunIndex3-H	0x0000 to 0xFFFF	0x0000	☆
AF-47	TPDO2-SunIndex3-L	0x0000 to 0xFFFF	0x0000	☆
AF-48	TPDO3-SunIndex0-H	0x0000 to 0xFFFF	0x0000	☆
AF-49	TPDO3-SunIndex0-L	0x0000 to 0xFFFF	0x0000	☆
AF-50	TPDO3-SunIndex1-H	0x0000 to 0xFFFF	0x0000	☆
AF-51	TPDO3-SunIndex1-L	0x0000 to 0xFFFF	0x0000	☆
AF-52	TPDO3-SunIndex2-H	0x0000 to 0xFFFF	0x0000	☆
AF-53	TPDO3-SunIndex2-L	0x0000 to 0xFFFF	0x0000	☆
AF-54	TPDO3-SunIndex3-H	0x0000 to 0xFFFF	0x0000	☆
AF-55	TPDO3-SunIndex3-L	0x0000 to 0xFFFF	0x0000	☆
AF-56	TPDO4-SunIndex0-H	0x0000 to 0xFFFF	0x0000	☆
AF-57	TPDO4-SunIndex0-L	0x0000 to 0xFFFF	0x0000	☆
AF-58	TPDO4-SunIndex1-H	0x0000 to 0xFFFF	0x0000	☆
AF-59	TPDO4-SunIndex1-L	0x0000 to 0xFFFF	0x0000	☆
AF-60	TPDO4-SunIndex2-H	0x0000 to 0xFFFF	0x0000	☆
AF-61	TPDO4-SunIndex2-L	0x0000 to 0xFFFF	0x0000	☆
AF-62	TPDO4-SunIndex3-H	0x0000 to 0xFFFF	0x0000	☆
AF-63	TPDO4-SunIndex3-L	0x0000 to 0xFFFF	0x0000	☆
AF-66	Number of valid RPDOs	0x0000 to 0xFFFF	0x0000	●
AF-67	Number of valid TPDOs	0x0000 to 0xFFFF	0x0000	●
Group B0: Control Mode, Linear Speed, and Winding Diameter				
B0-00	Tension control mode	0: Disabled 1: Open-loop tension torque control 2: Closed-loop tension speed control 3: Closed-loop tension torque control 4: Constant linear speed control	0	★
B0-01	Winding mode	0: Winding 1: Unwinding	0	☆
B0-02	Unwinding reverse tightening selection	0: Disabled 0.01 to 50.00m/min: linear speed of reverse tightening	0	☆
B0-03	Mechanical transmission ratio	0.01 to 300.00	1.00	☆
B0-04	Line speed setting channel	0: No input 1: AI1 2: AI2 4: Pulse input (DIO1) 5: Communication setting (1000H) 6: Communication setting (731 AH)	0	★

Appendix A Parameter Table

Para. No.	Para. Name	Setting Range	Default	Property
B0-05	Maximum linear speed	0.1 to 6500.0 m/min	1000.0 m/min	☆
B0-06	Minimum linear speed for winding diameter calculation	0.1 to 6500.0 m/min	20.0 m/min	☆
B0-07	Winding diameter calculation method	0: Calculated based on linear speed 1: Calculated based on accumulative thickness 2: AI1 3: AI2 5: Pulse input (DIO1)	0	★
B0-08	Maximum winding diameter	1 to 6000.0 mm	500.0 mm	☆
B0-09	Reel diameter	1 to 6000.0 mm	100.0 mm	☆
B0-10	Setting channel of initial winding diameter	0: B0-11 (Initial winding diameter 1) to B0-13 (Initial winding diameter 3) 1: AI1 2: AI2	0	★
B0-11	Initial winding diameter 1	1 to 6000.0 mm	100.0 mm	☆
B0-12	Initial winding diameter 2	1 to 6000.0 mm	100.0 mm	☆
B0-13	Initial winding diameter 3	1 to 6000.0 mm	100.0 mm	☆
B0-14	Current winding diameter	1 to 6000.0 mm	100.0 mm	☆
B0-15	Winding diameter filter time	0.00s to 10.00s	5.00s	☆
B0-16	Winding diameter change rate	0: Disabled 0.1 to 10.0 mm	1.0	☆
B0-17	Winding diameter change direction limit	0: Disabled 1: Decrease inhibited during winding, and increase inhibited during unwinding	0	☆
B0-18	Winding diameter reset during running	0: Disabled 1: Enabled	0	☆
B0-19	Pre-drive speed gain	-100.0% to 100.0%	0.0%	☆
B0-20	Pre-drive torque limit source	0: F2-09 [Torque limit source in speed control (motoring)] 1: Based on tension	1	★
B0-21	Pre-drive torque correction coefficient	-100.0% to 100.0%	0.0%	☆

Para. No.	Para. Name	Setting Range	Default	Property
B0-22	Pre-drive winding diameter calculation delay	0.1s to 6500.0s	10.0s	☆
B0-23	Pre-drive acceleration time (reserved)	0.0s to 6000.0s	0.0s	☆
B0-24	Pre-drive deceleration time (reserved)	0.0s to 6000.0s	0.0s	☆
B0-25	Pre-drive winding diameter calculation function	0: Disabled 1: Enabled	0	☆
B0-26	Closed-loop speed PID control limit (B0-00 = 2)	0.0% to 100.0%	50.0%	☆
	Speed limit (B0-00 ≠ 2)	0.0% to 100.0%		
B0-27	Closed-loop speed PID control limit offset (B0-00 = 2)	0.00 to 100.00 Hz	5.00 Hz/%	☆
	Speed limit offset (B0-00 ≠ 2)	0.00% to 100.00%		
B0-28	Closed-loop speed PID control limit selection (B0-00 = 2)	0: Limit by B0-26 and B0-27 1: Limit by B0-27	0	☆
	Speed limit selection (B0-00 ≠ 2)	0: Disabled (limited by maximum frequency F0-10) 1: Limit by B0-26 and B0-27		
B0-29	Number of pulses per revolution	1 to 60000	1	☆
B0-30	Revolutions per layer	1 to 10000	100	☆
B0-31	Setting channel of material thickness (reserved)	0: Digital setting 1: AI1 2: AI2	0	☆
B0-32	Material thickness 0	0.01 to 100.00 mm	0.01 mm	☆
B0-33	Material thickness 1	0.01 to 100.00 mm	0.01 mm	☆
B0-34	Material thickness 2	0.01 to 100.00 mm	0.01 mm	☆
B0-35	Material thickness 3	0.01 to 100.00 mm	0.01 mm	☆
B0-36	Maximum thickness	0.01 to 100.00 mm	1.00 mm	☆
B0-38	Closed-loop tension torque mode main + auxiliary torque	0: Disabled 1: Enabled	1	☆
B0-40	Unwinding electric	0: Disabled 1: Enabled	0	☆

Appendix A Parameter Table

Para. No.	Para. Name	Setting Range	Default	Property
B0-41	Constant line speed input source	0: AI1 1: AI2 3: Pulse input 4: Communication setting (1000H) 5: Communication setting (731AH)	0	★
Group B1: Tension Setting				
B1-00	Tension setting channel	0: B1-01 1: AI1 2: AI2 4: Pulse reference 5: Communication setting	0	★
B1-01	Tension digital setting	0 to 65,000 N	50 N	☆
B1-02	Maximum tension	0 to 65,000 N	200 N	☆
B1-03	Zero-speed threshold	0.00% to 20.0% (maximum frequency, F0-10)	0.0%	☆
B1-04	Zero-speed tension rise	0.0 to 1000.0%	0.0%	☆
B1-05	Frequency acceleration time in torque control mode (reserved)	0s to 6500.0s	0.0s	☆
B1-06	Frequency deceleration time in torque mode (reserved)	0s to 6500.0s	0.0s	☆
B1-07	Friction force compensation coefficient	0.0% to 50.0%	0.0%	☆
B1-08	Mechanical inertia compensation coefficient	0 to 65535 N · m ²	0 N · m ²	☆
B1-09	Correction coefficient of acceleration inertia compensation	0.0% to 200.0%	100.0%	☆
B1-10	Correction coefficient of deceleration inertia compensation	0.0% to 200.0%	100.0%	☆
B1-11	Material density	0 to 60000 Kg/m ³	0 Kg/m ³	☆
B1-12	Material width	0 to 60,000 mm	0 mm	☆
B1-13	Inertia compensation exit delay	0 to 1000 ms	0 ms	☆
B1-16	Torque closed-loop PID control limit	0.0% to 100.0%	50.0%	☆

Para. No.	Para. Name	Setting Range	Default	Property
B1-17	Friction force compensation correction coefficient	-50.0% to 50.0%	0.0%	☆
B1-18	Friction force compensation curve	0: Frequency 1: Linear speed 2: Multi-friction force compensation curve 1 3: Multi-friction force compensation curve 2	0	★
B1-19	Multi-friction force compensation torque 1	0.0 to 50.0%	0.0%	☆
B1-20	Multi-friction force compensation torque 2	0.0 to 50.0%	0.0%	☆
B1-21	Multi-friction force compensation torque 3	0.0 to 50.0%	0.0%	☆
B1-22	Multi-friction force compensation torque 4	0.0 to 50.0%	0.0%	☆
B1-23	Multi-friction force compensation torque 5	0.0 to 50.0%	0.0%	☆
B1-24	Multi-friction force compensation torque 6	0.0 to 50.0%	0.0%	☆
B1-25	Multi-friction force compensation inflection 1	0.00 Hz to maximum frequency (F0-10)	0.00 Hz	☆
B1-26	Multi-friction force compensation inflection2	0.00 Hz to maximum frequency (F0-10)	0.00 Hz	☆
B1-27	Multi-friction force compensation inflection3	0.00 Hz to maximum frequency (F0-10)	0.00 Hz	☆
B1-28	Multi-friction force compensation inflection4	0.00 Hz to maximum frequency (F0-10)	0.00 Hz	☆
B1-29	Multi-friction force compensation inflection5	0.00 Hz to maximum frequency (F0-10)	0.00 Hz	☆
B1-30	Multi-friction force compensation inflection 6	0.00 Hz to maximum frequency (F0-10)	0.00 Hz	☆
B1-31	Tension establishment	0: Disabled 1: Enabled	0	★
B1-32	Tension establishment dead zone	0.0% to 100.0%	1.0%	★
B1-33	Tension establishment frequency	0.00 Hz to F0-10 (Maximum frequency)	0.05 Hz	★

Appendix A Parameter Table

Para. No.	Para. Name	Setting Range	Default	Property
B1-34	Tension establishment Kp (only closed-loop speed mode)	0.0% to 100.0%	1.0%	★
B1-35	Tension establishment Ki (only closed-loop speed mode)	0.00s to 20.00s	10.00s	★
B1-37	Initial winding diameter free	0: Disabled 1: Enabled	0	★
B1-38	Rod length	1 to 65535 mm	300 mm	★
B1-39	Rod angle	1.0° to 360.0°	40.0°	★
Group B2: Tension Taper				
B2-00	Taper curve	0: Curved 1: Linear	0	★
B2-01	Setting channel of tension taper	0: Set by B2-02 (Tension taper) 1: AI1 2: AI2	0	★
B2-02	Tension taper	0.0% to 100.0%	0.0%	☆
B2-03	Correction value of tension taper compensation	0.00 to 10,000 mm	0 mm	☆
B2-04	Closed-loop tension taper function	0: Disabled 1: Enabled	0	★
B2-05	Setting channel of maximum external taper	0: Set by B2-06 (Maximum external taper) 1: AI1 2: AI2	0	★
B2-06	Maximum external taper	0.0% to 100.0%	100.0%	☆
B2-07	Linear taper inflexion quantity	0 to 5	5	☆
B2-08	Taper corresponding to minimum reel diameter	0.0% to 100.0%	100.0%	☆
B2-09	Linear taper switchover point 1	B0-09 (Reel diameter) to B0-08 (Maximum winding diameter)	150.0 mm	☆
B2-10	Taper of switchover point 1	0.0% to 100.0%	100.0%	☆
B2-11	Linear taper switchover point 2	B2-09 (Linear taper switchover point 1) to B0-08 (Maximum winding diameter)	200.0 mm	☆
B2-12	Taper of switchover point 2	0.0% to 100.0%	90.0%	☆

Para. No.	Para. Name	Setting Range	Default	Property
B2-13	Linear taper switchover point 3	B2-11 (Linear taper switchover point 2) to B0-08 (Maximum winding diameter)	250.0 mm	☆
B2-14	Taper of switchover point 3	0.0% to 100.0%	80.0%	☆
B2-15	Linear taper switchover point 4	B2-13 (Linear taper switchover point 3) to B0-08 (Maximum winding diameter)	300.0 mm	☆
B2-16	Taper of switchover point 4	0.0% to 100.0%	70.0%	☆
B2-17	Linear taper switchover point 5	B2-15 (Linear taper switchover point 4) to B0-08 (Maximum winding diameter)	400.0 mm	☆
B2-18	Taper of switchover point 5	0.0% to 100.0%	50.0%	☆
B2-19	Taper corresponding to maximum winding diameter	0.0% to 100.0%	30.0%	☆
B2-20	Taper corresponding to maximum reel diameter	0.0% to 100.0%	30.0%	☆

A.2 Monitoring Parameters

Parameter No.	Parameter Name	Minimum Unit	Communication Address
Group U0: Basic Monitoring Parameters			
U0-00	Running frequency	0.01 Hz	7000H
U0-01	Frequency reference	0.01 Hz	7001H
U0-02	Bus voltage	0.1 V	7002H
U0-03	Output voltage	1 V	7003H
U0-04	Output Current	0.1 A	7004H
U0-05	Output power	0.1 kW	7005H
U0-06	Output torque	0.1%	7006H
U0-07	DI state	1	7007H
U0-08	DO state	1	7008H
U0-09	AI1 voltage	0.01 V	7009H
U0-10	AI2 voltage	0.01 V	700AH
U0-11	Motor speed	1 RPM	700BH
U0-12	Count value	1	700CH
U0-13	Length value	1	700DH
U0-14	Load speed display	1	700EH

Appendix A Parameter Table

Parameter No.	Parameter Name	Minimum Unit	Communication Address
U0-15	PID reference	1%	700FH
U0-16	PID feedback	1%	7010H
U0-17	PLC stage	1	7011H
U0-18	Pulse frequency	0.01 kHz	7012H
U0-19	Feedback frequency	0.01 Hz	7013H
U0-20	Remaining running time	0.1 min	7014H
U0-21	AI1 voltage before correction	0.001 V	7015H
U0-22	AI2 voltage before correction	0.001 V	7016H
U0-24	Linear speed	1 m/min	7018H
U0-25	Accumulative power-on time	1 min	7019H
U0-26	Accumulative running time	0.1 min	701AH
U0-27	Pulse frequency	1 Hz	701BH
U0-28	Communication setting	0.01%	701CH
U0-29	Encoder feedback frequency	0.01 Hz	701DH
U0-30	Main frequency reference	0.01 Hz	701EH
U0-31	Auxiliary frequency reference	0.01 Hz	701FH
U0-33	Synchronous motor rotor position	0.1°	7021H
U0-34	Motor temperature	1° C	7022H
U0-35	Target torque	0.1%	7023H
U0-37	Power factor angle	0.1°	7025H
U0-39	Target voltage upon V/F separation	1 V	7027H
U0-40	Output voltage upon V/F separation	1 V	7028H
U0-41	DI state display	1	7029H
U0-42	DO state display	1	702AH
U0-45	Fault subcode	1	702DH
U0-46	Heatsink temperature	1° C	702EH
U0-47	Voltage before PTC correction	0.001 V	702FH
U0-48	Voltage after PTC correction	0.001 V	7030H
U0-49	Pulses for position lock deviation	1	7031H
U0-58	Encoder Z signal counting	1	703AH
U0-59	Frequency reference	0.01%	703BH
U0-60	Running frequency	0.01%	703CH

Parameter No.	Parameter Name	Minimum Unit	Communication Address
U0-61	Drive state 1 (1: Forward running; 2: Reverse running; 3: Stopped; 4: Auto-tuning; 5: Faulty)	1	703DH
U0-62	Fault code	1	
U0-68	Drive state 2	1	7044H
U0-69	Feedback frequency	0.01Hz	7045H
U0-74	Target torque after filtering	0.1%	704AH
U0-75	Target torque after acceleration and deceleration	0.1%	704BH
U0-76	Target torque upper limit	0.1%	704CH
U0-77	Regenerative torque upper limit	0.1%	704DH
Group U1: Tension Monitoring Parameters			
U1-00	Current linear speed	0.1 m/min	7100H
U1-01	Current winding diameter	0.1 mm	7101H
U1-02	Line speed mapping frequency	0.01 Hz	7102H
U1-03	Current tension reference	1 N	7103H
U1-04	Tension after taper calculation	1 N	7104H
U1-05	Tension calculation torque	0.1%	7105H
U1-16	Torque PID reference	0.1%	7110H
U1-17	Torque PID feedback	0.1%	7111H
U1-18	Torque PID output	0.1%	7112H
U1-19	Frequency PID reference	0.1%	7113H
U1-20	Frequency PID feedback	0.1%	7114H
U1-21	Frequency PID output	0.01 Hz	7115H

INOVANCE Warranty Agreement

- 1) Inovance provides an 18-month free warranty to the equipment itself from the date of manufacturing for the failure or damage under normal use conditions.
- 2) Within the warranty period, maintenance will be charged for the damage caused by the following reasons:
 - a. Improper use or repair/modification without prior permission
 - b. Fire, flood, abnormal voltage, natural disasters and secondary disasters
 - c. Hardware damage caused by dropping or transportation after procurement
 - d. Operations not following the user instructions
 - e. Damage out of the equipment (for example, external device factors)
- 3) The maintenance fee is charged according to the latest Maintenance Price List of Inovance.
- 4) If there is any problem during the service, contact Inovance's agent or Inovance directly.
- 5) Inovance reserves the rights for explanation of this agreement.

Suzhou Inovance Technology Co., Ltd.

Address: No.16, Youxiang Road, Yuexi Town, Wuzhong District, Suzhou 215104, P.R. China

Website: <http://www.inovance.com>

