

# CFW10

## Variable Speed Drive

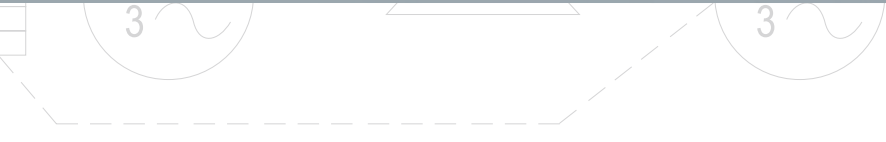

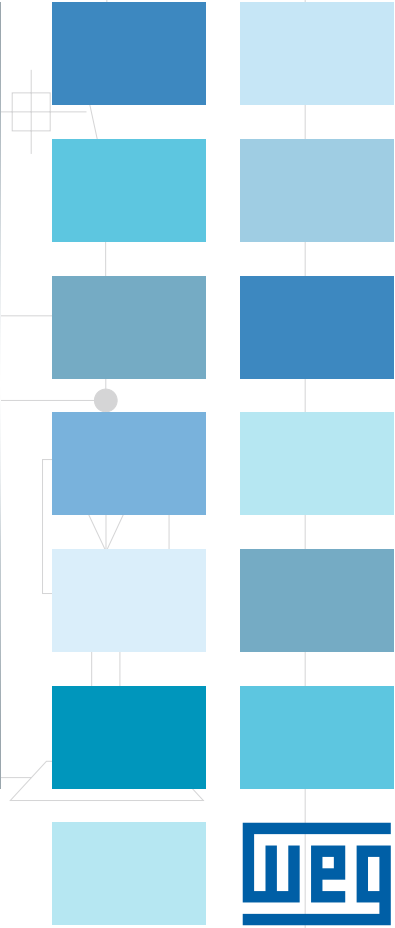
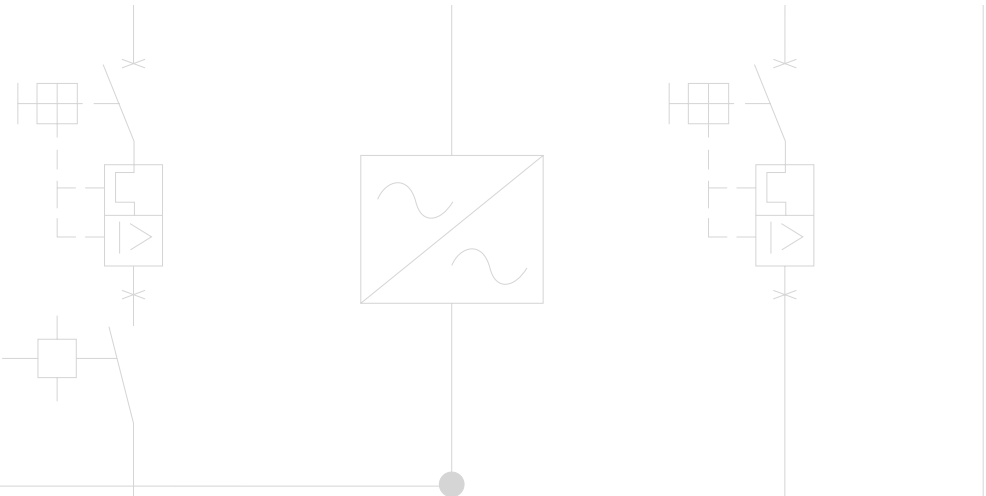

## VSD

VSDs are intended for speed control of three-phase induction motors in a wide variety of industrial applications. The WEG VSD series offers state-of-the-art technology in motor control with a modern design, great number of features, and easy installation and operation.

These products are designed with high-software optimization and are easily set through a simple Human-Machine Interface (keypad). Additionally, they comprise functions and resources that allow protection and control of electric motors an extremely easy and efficient way. They are suitable to operate with V/f or vector control.

## CFW10

The CFW10 VSD line is designed for the control and speed variation of three-phase induction motors. CFW10 combines modern design with cutting-edge technology, and stands out for its small profile and easy programming. In addition, CFW10 is simple to install and operate, due to its built-in standard keypad.

### Features

- V/f control
- IP20 finger-safe enclosure
- Single-phase 110-127 line voltage up to 0.75 kW / 1 hp
- Single-phase 200-240 line voltage up to 2.2 kW / 3 hp
- Three-phase 200-240 line voltage up to 4 kW / 5 hp
- 150% current overload capacity
- DSP controlled PWM output
- 2.5 - 15 kHz adjustable switching frequency
- Four isolated programmable digital inputs
- Programmable relay output
- One isolated programmable analog input
- Motor and VSD protections: overcurrent, motor overload, drive overtemperature, output short circuit, DC link over and undervoltage, and external fault
- Control features: linear and "S" acceleration and deceleration ramps, local/remote control, DC braking, torque boost, motor slip compensation, electronic pot, preset speeds, maximum and minimum adjustable frequency limits, adjustable output current limit, JOG function
- Display readings: motor speed, frequency, voltage, current, last fault, heatsink temperature and drive status
- Ambient: 50 °C (122 °F), 1,000 m (3,300 ft) altitude, 90% humidity, non-condensing.



### Certifications



# Applications

- Centrifugal pumps
  - Processing pumps
  - Fans / exhaust fans
  - Stirrers / mixers
- Extruding machines
  - Roller tables
  - Driers
- Rotating filters
  - Cutting machines
  - Conveyors



## Block Diagram

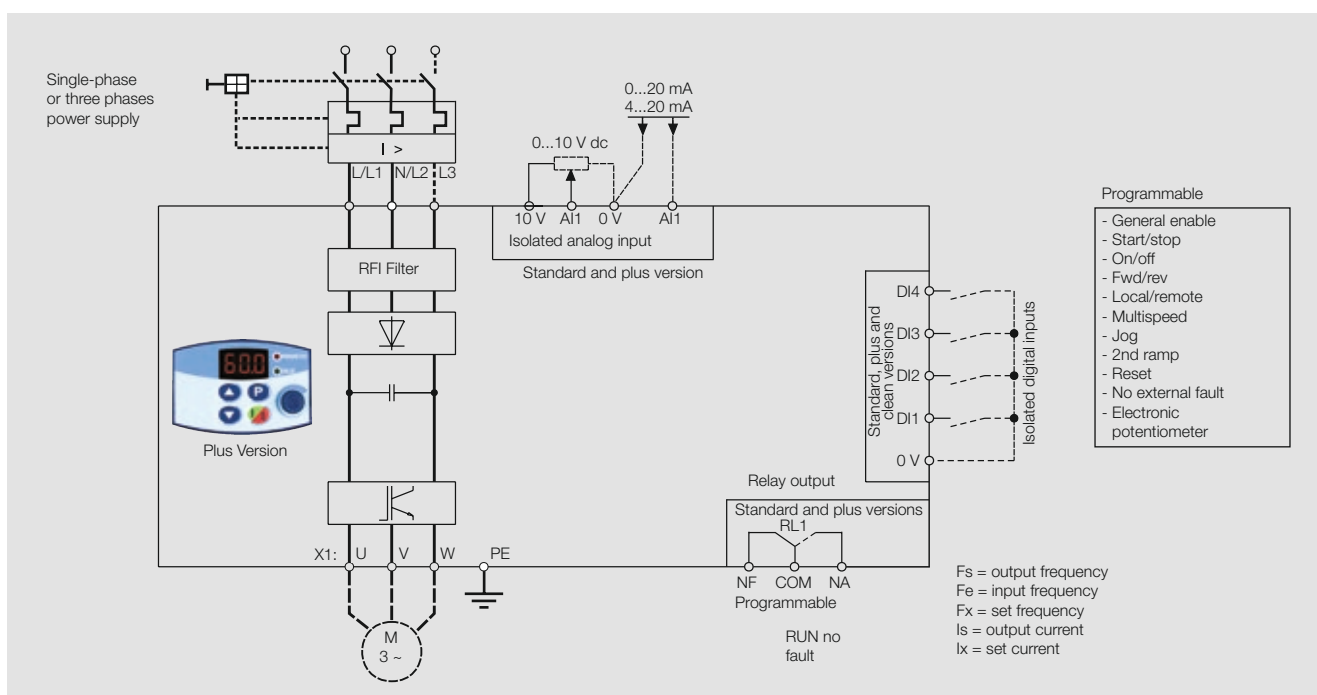



## Drive Ratings

The correct way to select a VSD is matching its output current with the motor rated current. However, the table below presents the expected motor power for each VSD model.

Use the motor power ratings below only as a guidance. Motor rated currents may vary with speed and manufacturer. IEC motor powers are based on WEG 4-pole motors; NEMA motor powers are based on NEC table 430-150.

### Motor Voltages Between 220 V and 230 V

Power supply		Model	Output current
			A
110-127 V	10	CFW100016S1112	1.6
		CFW100026S1112	2.6
		CFW100040S1112	4
220-230 V	10 / 30	CFW100016S2024	1.6
		CFW100026S2024	2.6
		CFW100040S2024	4
		CFW100073S2024	7.3
		CFW100100S2024	10
		CFW100016T2024	1.6
	30	CFW100026T2024	2.6
		CFW100040T2024	4
		CFW100073T2024	7.3
		CFW100100T2024	10
		CFW100152T2024	15.2

IEC	NEMA
50 Hz 220 V 230 V	60 Hz 230 V
kW	HP
0.25	-
0.55	0.5
0.75	0.75
0.25	-
0.55	0.5
0.75	0.75
1.5	2
2.2	3
0.25	-
0.55	0.5
0.75	0.75
1.5	2
2.2	3
4	5



## “Cold Plate” - Drive Ratings

Power supply voltage	CFW10 cold plate				Maximum applicable motor			Frame size	Dimensions mm (in)			Weight kg (lb)
	Number of phases	Model	In output (A)	Braking transistor	Voltage (V)	Power rating			H	W	D	
						kW	HP					
110-127 V	Single phase	CFW100016S1112E0CPZ	1.6		230	0.18	0.25	1	132 (5.2)	100 (3.9)	82 (3.2)	0.7 (1.5)
		CFW100026S1112E0CPZ	2.6			0.37	0.5	1				161 (6.3)
CFW100040S1112E0CPZ		4.0		0.75		1	2	132 (5.2)	100 (3.9)	0.7 (1.5)		
CFW100016S2024E0CPZ		1.6		0.18		0.25	1					161 (6.3)
CFW100026S2024E0CPZ		2.6		0.37		0.5	1	191 (7.5)	120 (4.7)	1.2 (2.6)		
CFW100040S2024E0CPZ		4.0		0.75		1	1					132 (5.2)
200-240 V	Single phase	CFW100073S2024E0CPZ	7.3			1.5	2	2	161 (6.3)	120 (4.7)	1.0 (2.2)	
		CFW100100S2024E0CPZ	10			2.2	3	3				191 (7.5)
		Three phases 1)	CFW100016T2024E0CPZ	1.6			0.18	0.25	1	132 (5.2)	100 (3.9)	
			CFW100026T2024E0CPZ	2.6			0.37	0.5	1			161 (6.3)
			CFW100040T2024E0CPZ	4.0			0.75	1	1	191 (7.5)	120 (4.7)	
			CFW100073T2024E0CPZ	7.3			1.5	2	1			132 (5.2)
	CFW100100T2024E0CPZ	10.0		2.2	3	2	161 (6.3)	120 (4.7)	1.0 (2.2)			
	CFW100152T2024E0CPZ	15.2		4	5	3				191 (7.5)	120 (4.7)	1.2 (2.6)

Note: 1) CE Certification pending.

## Dimensions and Weight

Model	Standard frame size					Cold plate version					Braking IGBT
	Frame size	Dimensions mm (in)			Weight kg (lb)	Frame size	Dimensions mm (in)			Weight kg (lb)	
		H	W	D			H	W	D		
CFW100016S1112	1	95	132	121	0.9	1	95	132	82	0.7	No
CFW100026S1112		(3.74)	(5.20)	(4.76)	(1.98)		(3.74)	(5.20)	(3.23)	(1.54)	
CFW100040S1112	2	115	161	122	1.5	2	115	161	82	1.0	Yes
CFW100016S2024	1	95	132	121	0.9	1	95	132	82	0.7	No
CFW100026S2024		(3.74)	(5.20)	(4.76)	(1.98)		(3.74)	(5.20)	(3.23)	(1.54)	
CFW100040S2024		(4.53)	(6.34)	(4.80)	(3.31)		(4.53)	(6.34)	(3.23)	(2.20)	
CFW100073S2024	2	115	161	122	1.5	2	115	161	82	1.0	Yes
CFW100100S2024	3	115	191	122	1.8	3	115	191	82	1.2	
CFW100016T2024	1	95	132	121	0.9	1	95	132	82	0.7	No
CFW100026T2024		(3.74)	(5.20)	(4.76)	(1.98)		(3.74)	(5.20)	(3.23)	(1.54)	
CFW100040T2024		(4.53)	(6.34)	(4.80)	(3.31)		(4.53)	(6.34)	(3.23)	(2.20)	
CFW100073T2024		(7.52)	(9.84)	(4.80)	(3.96)		(7.52)	(10.16)	(3.23)	(2.65)	
CFW100100T2024	2	115	161	122	1.5	2	115	161	82	1.0	Yes
CFW100152T2024	3	115	191	122	1.8	3	115	191	82	1.2	
		(4.53)	(7.52)	(4.80)	(3.96)		(4.53)	(7.52)	(3.23)	(2.65)	

# Technical Data

Model		CFW10 Standard	CFW10 Clean	CFW10 plus
Power supply	Voltage	Single phase	110 - 127 V ac: 110 / 127 V ac (+10%, -15%)	
		Single phase or Three phases	200 - 240 V ac (+10%, -15%)	
	Frequency		50 / 60 Hz, +/- 2 Hz (48 - 62 Hz)	
	cos φ (displacement power factor)		> 0.98	
Enclosure	Degree of protection		IP20	
Control	Power supply		Switched mode power supply	
	Control method		Sinusoidal PWM modulation (space vector modulation), linear or quadratic V/f	
	Switching frequency		Frequencies: from 2.5 kHz to 15 kHz	
	Output frequency		0 - 300 Hz	
	Frequency setting resolution		Analog ref.: 0.1% of max. frequency and digital ref.: 0.01 Hz (f<100 Hz); 0.1 Hz (f>100 Hz)	
Performance	Output frequency accuracy		Analog ref.: 0.5% digital ref.: 0.01%	
	Overload capacity		150% during 60s every 10min.	
Control inputs	Analog	1 programmable isolated input 0 - 10 V dc, 0 - 20 mA or 4 - 0 mA	-	1 programmable isolated input 0 - 10 V dc, 0 - 20 mA or 4 - 0 mA
	Digital	4 programmable isolated inputs 12 V dc		
Control outputs	Relay	1 programmable output, form C contacts (NO/NC)	-	1 programmable output, form C contacts (NO/NC)
		Programming options: Is > Ix; Fs > Fx; Fe > Fx; Fs = Fe; Run; No Fault		
Safety	Protections	DC link overvoltage / undervoltage		
		VSD overtemperature		
		Keypad connection fault		
		Motor overload (i x t)		
		CPU error (watchdog), external fault		
		Output short-circuit		
Keypad	Programming	Start/stop		
	Commands	Parameters setting		
		Frequency UP/down (speed)		
	Monitoring	-	-	Variable speed potentiometer
		Motor output frequency (Hz)		
		DC link voltage (V dc)		
		Value proportional to the frequency (e.d.: rpm)		
		Heatsink temperature		
Output current (Amps)				
Output voltage				
Fault indication				
Ambient	Temperature	Models up to 10 A: 0 ... 50 °C (32 ... 122 °F) without derating 15.2 A model: 0 ... 40 °C (32 ... 104 °F) without derating		
	Humidity	5 ... 90% non-condensing		
	Altitude	0 ... 1,000 m (3,300 ft), up to 4,000 m (13,100 ft) with 1%/100 m (3%/1,000 ft) output current derating		
Enclosure	Color		Opaque gray - WEG development 205E1404	
Conformities	Electromagnetic compatibility		EMC directive 89 / 336 / EEC EN 61800-3	
	Low voltage		LVD 73/23/EEC - low voltage directive / UL 508C	
Features	Standard	Keypad with 7-segment LED display		
		Password to protect VSD programming		
		Self-diagnosis fault and auto-reset		
		Motor slip compensation		
		Manual and automatic torque boost (I x R)		
		Linear and "S" acceleration ramp, two sets of ramps		
		JOG function		
		DC braking		
		Multi-speed function (up to 8 programmable speeds)		
		Forward/reverse speed selection via DI		
Local/remote reference selection via DI				

# Coding

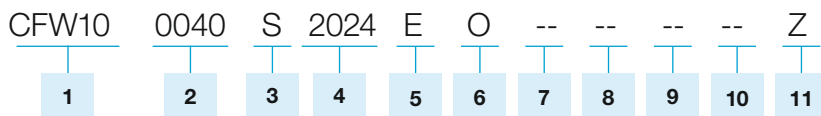

## 1 - CFW10 VSD series

### 2 - Output rated current:

110-127 V		200-240 V	
0016	1.6 A	0016	1.6 A
0026	2.6 A	0026	2.6 A
0040	4.0 A	0040	4.0 A
		0073	7.3 A
		0100	10.0 A
		0152	15.2 A

\* Three-phase model only.

### 3 - Number of phases

S = single phase  
T = three phases

### 4- Power supply voltage

1,112 = 110 - 127 V (single-phase only)  
2,024 = 200 - 240 V

### 5 - Manual language

P = portuguese  
E = english  
S = spanish

### 6 - Options

S = standard (no optionals)  
O = with optionals

### 7 - Control card

Blank = standard  
CL = clean (without analog input and relay output)  
PL = plus (with potentiometer)

### 8- EMC filter

Blank = without filter  
FA = with built-in class A EMC filter  
(only 200 - 240 V single-phase models)

### 9 - Special hardware

Blank = standard (no special hardware)  
Hx = special hardware in version X  
CP = Cold Plate heatsink version

### 10 - Special software

Blank = standard (no special software)  
Sx = special software in version X

### 11 - End of code

Ex.: CFW100040S2024ESZ VSD of CFW10 series, 4.0 A, single -phase at 200 - 240 V ac and manual in english.

# WEG Worldwide Operations